

THIS DRAWING AND ALL INFORMATION CONTAINED HEREIN IS THE PROPERTY OF WELDON TECHNOLOGIES, INC. AND MAY NOT BE COPIED, REPRODUCED, OR DEVELOPED TO UNAUTHORIZED PERSONS WITHOUT THE EXPRESS WRITTEN CONSENT OF WELDON TECHNOLOGIES, INC. AS IT IS BEING PROVIDED SOLELY FOR THE CONVENIENCE OF THE USER AND SHALL BE RETURNED TO WELDON TECHNOLOGIES, INC. UPON REQUEST.

REV		DATE	DESCRIPTION	BY	DATE	APPROV
A	PROJ22		RELEASE TO PRODUCTION	GD	7/20/04	ST
B	0613		CHANGED R13 TO ZERO OHMS	GD	6/21/05	ST

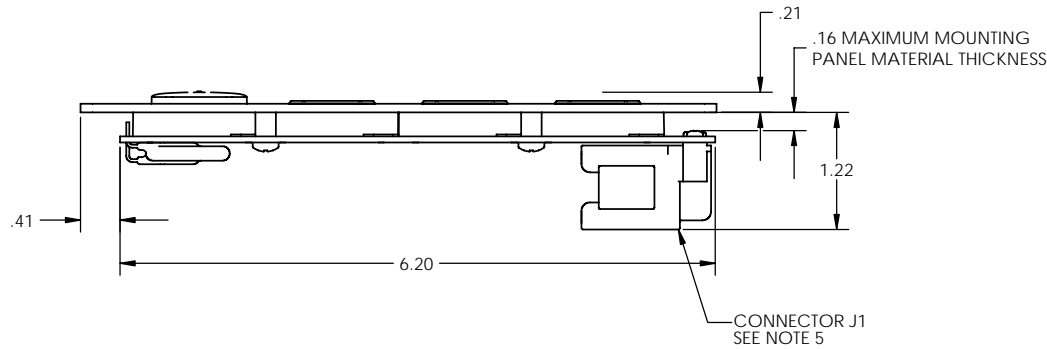
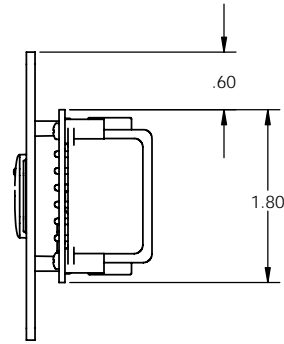
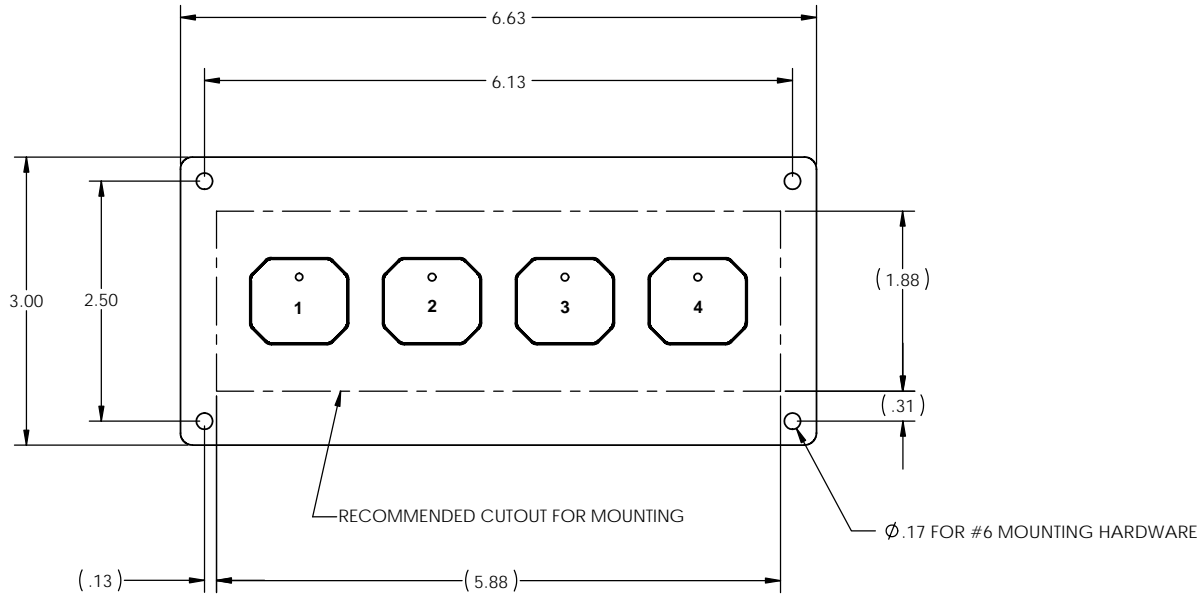

ATTENTION: THIS UNIT IS INTENDED FOR DRY (INTERIOR) APPLICATIONS ONLY.

J1 CONNECTOR PINOUT	
MATING CONNECTOR - DEUTSCH DT06-12S	
PIN #	DESCRIPTION
1	KEY 1 INDICATOR LED
2	NORMALLY-OPEN KEY 1
3	KEY 2 INDICATOR LED
4	KEY 4 INDICATOR LED
5	KEY 3 INDICATOR LED
6	+12 VDC
7	NORMALLY-OPEN KEY 4
8	NORMALLY-OPEN KEY 3
9	NORMALLY-OPEN KEY 2
10	KEYSWITCH COMMON (+12 V OR GND)
11	LED BACKLIGHT (+12 V)
12	GROUND

CAUTION: A REVERSE BATTERY CONDITION (PINS 6 AND 12) WILL PERMANENTLY DAMAGE THE DEVICE.

NOTES:

- WHEN INSTALLING THE SWITCH PANEL, DO NOT APPLY POWER UNTIL THE UNIT IS SECURELY MOUNTED.
- CLEAR, ACRYLIC, KEY CAPS ARE SHIPPED WITH EACH PANEL TO ALLOW FOR THE INSTALLATION OF CUSTOM KEY LEGENDS. BLANK SHEETS OF LASER-PRINTABLE KEY LEGENDS ARE AVAILABLE (WELDON P/N 0020-1736-00) WITH 88 DIE-CUT LEGENDS PER SHEET. AFTER THE APPROPRIATE LEGEND IS INSTALLED, SIMPLY PUSH THE CLEAR, KEY CAP OVER THE KEY.
- SWITCHES MAY PRESENT EITHER +12 V OR GROUND AT THEIR OUTPUTS. THE SELECTION IS MADE BY TYING KEYSWITCH COMMON (PIN #10) TO GROUND OR +12 V.
- SWITCH INDICATOR LED'S ARE OPERATED INDEPENDENTLY OF THE PHYSICAL SWITCH AND MUST BE DRIVEN BY AN EXTERNAL +12V SOURCE. INDICATOR LED DRIVE IS LESS THAN 20mA PER SWITCH.
- MATING CONNECTOR IS A DEUTSCH P/N DT06-12SA.
- SPECIFICATIONS: OPERATING TEMPERATURE RANGE IS -40°C TO +85°C
OPERATING VOLTAGE RANGE IS +9 VDC TO +16 VDC.

UNLESS OTHERWISE SPECIFIED DIMENSIONS ARE IN INCHES TOLERANCES ARE: XXX - .0100 XX - .0020 X - .0010 ANGLES - .015°	CADD GENERATED DRAWING DO NOT MANUALLY UPDATE		WELDON TECHNOLOGIES, INC.	
	APPROVALS	DATE	CUSTOMER DRAWING 4-KEY STATIC SWITCH PANEL	
DRAWN	GD	7/12/04		
MATERIAL	CHECKED	ST	7/16/04	
FINISH	MFG ENG			
DO NOT SCALE DRAWING	QUAL ENG			
PROJECT NO.	00131	SCALE	1:1	
PART NO.	C6300-0400-00	REV	B	
WELDON COMPUTER GRAPHICS		SHEET 1 OF 1		