

THIS DRAWING AND ALL INFORMATION CONTAINED HEREIN IS THE PROPERTY OF WELDON TECHNOLOGIES, INC. AND MAY NOT BE COPIED, REPRODUCED, OR DIVULGED TO UNAUTHORIZED PERSONS WITHOUT THE EXPRESS WRITTEN CONSENT OF WELDON TECHNOLOGIES, INC. AS IT IS BEING PROVIDED SOLELY FOR THE CONVENIENCE OF THE USER AND SHALL BE RETURNED TO WELDON TECHNOLOGIES, INC. UPON REQUEST.

| REVISIONS |     |                 |      |           |
|-----------|-----|-----------------|------|-----------|
| REV.      | ECN | DESCRIPTION     | DATE | BY / APVD |
| A         | --  | DRAWING RELEASE | --   | TB        |

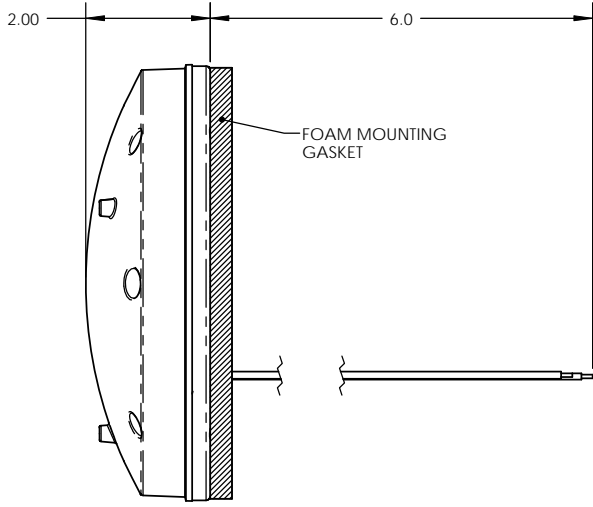
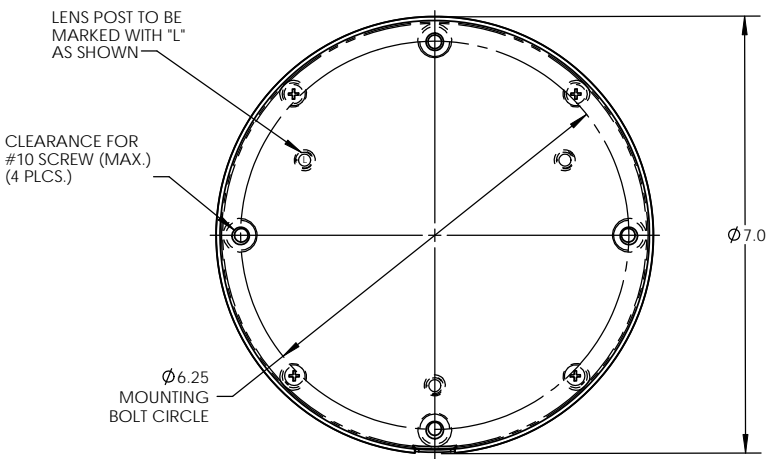

- NOTES:
- LAMP TO COMPLY WITH SAE J887 AS REFERENCED BY THE FEDERAL MOTOR VEHICLE SAFETY STANDARD NO. 108.
  - LENS MATERIAL MUST COMPLY WITH SAE J576 - PLASTIC MATERIALS FOR USE IN OPTICAL PARTS.
  - LAMP SHALL MEET 48 HOUR CORROSION TEST PER SAE J575.
  - LENS POST AND LAMP BODY SHALL BE MARKED WITH "L".
  - MOUNTING GASKET TO BE ATTACHED TO LAMP BODY.
  - NOMINAL OPERATING VOLTAGE = 13.2 VDC.
  - NOMINAL OPERATING CURRENT = 4.7 AMPS
  - OPERATING TEMPERATURE RANGE = -40C TO +55C
  - WIRE COLOR/FUNCTION  
BLACK = POWER  
WHITE = GROUND

| PART NUMBER  | LENS COLOR/MATERIAL |
|--------------|---------------------|
| 1080-1106-10 | RED POLYCARBONATE   |
| 1080-1106-20 | AMBER POLYCARBONATE |

|  |   |         |                                  |   |
|--|---|---------|----------------------------------|---|
| UNLESS OTHERWISE SPECIFIED DIMENSIONS ARE IN INCHES TOLERANCES ARE:<br>X.XXX - ±0.005<br>X.XX - ±0.020<br>X.X - ±0.050<br>ANGLES - ±0.5° | CAD GENERATED DRAWING. DO NOT MANUALLY UPDATE |         | <b>WELDON TECHNOLOGIES, INC.</b> |   |
|  | APPROVALS                                     | DATE    |                                  |   |
|  | DRAWN   | BARNETT | 8/12/10                          | CUSTOMER DRAWING<br>WARNING LAMP<br>FLAT BACK HALOGEN; 2-WIRE |
|  | CHECKED                                       |         |                                  |   |
| QUAL ENG   |   |         |                                  |   |
| MATERIAL   |   |         |                                  |   |
| FINISH   |   |         |                                  |   |
| DO NOT SCALE DRAWING   | PROJ. NO.                                     |         | SIZE B                           | PART NO. C1080-1106-10  |
|  |   |         | SCALE: 1:1                       | REV. A  |

WELDON COMPUTER GRAPHICS SHEET 1 OF 1