

THIS DRAWING AND ALL INFORMATION CONTAINED HEREIN IS THE PROPERTY OF WELDON TECHNOLOGIES, INC. AND MAY NOT BE COPIED, REPRODUCED, OR DIVULGED TO UNAUTHORIZED PERSONS WITHOUT THE EXPRESS WRITTEN CONSENT OF WELDON TECHNOLOGIES, INC. AS IT IS BEING PROVIDED SOLELY FOR THE CONVENIENCE OF THE USER AND SHALL BE RETURNED TO WELDON TECHNOLOGIES, INC UPON REQUEST.

REVISIONS				
REV.	ECN	DESCRIPTION	DATE	BY APVD
A	R0497	RELEASE FOR REFERENCE	1/28/04	ST TB

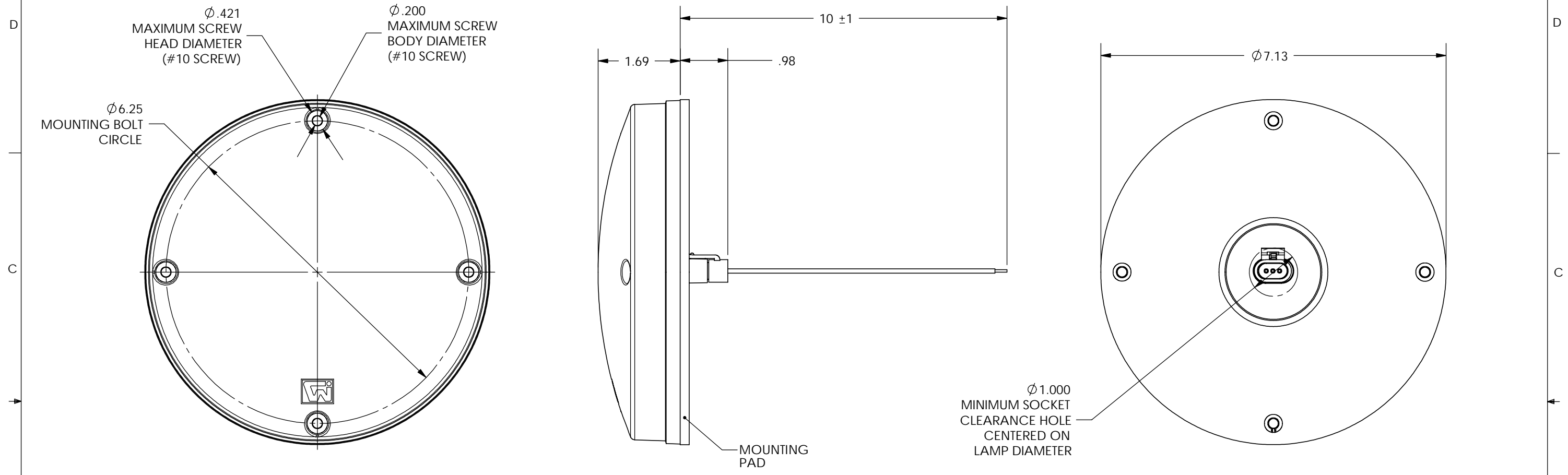

- NOTES:
 1. INPUT VOLTAGE: 10-16VDC (12.8 NOMINAL)
 2. OPERATING TEMP: -40 TO +55C
 3. STANDARD PACK QTY: 12 LAMPS PER CARTON.

PART NUMBER	WIRE FUNCTION			SERVICE PARTS	
	RED	BLACK	WHITE	LAMP	PLUG
1010-8110-10	STOP	TAIL	GROUND	1010-8100-10	0K90-1549-20
1010-8110-20	TURN	PARK	GROUND	1010-8100-20	0K90-1549-20
1010-8110-30	POWER	--	GROUND	1010-8100-30	0K90-1549-10

UNLESS OTHERWISE SPECIFIED DIMENSIONS ARE IN INCHES TOLERANCES ARE: X.XXX - ±0.005 X.XX - ±0.020 X.X - ±0.050 ANGLES - ±0.5°	CAD GENERATED DRAWING. DO NOT MANUALLY UPDATE		WELDON TECHNOLOGIES, INC.	
	APPROVALS	DATE		
	DRAWN	ST	1/28/04	CUSTOMER DRAWING 7" ROUND L.E.D. LAMP W/ PLUG ASSEMBLY
	CHECKED	TB	1/28/04	
MATERIAL			SIZE B PART NO. C1010-8110-00 REV. A	
FINISH			SCALE: 1:2 WELDON COMPUTER GRAPHICS SHEET 1 OF 1	
DO NOT SCALE DRAWING	PROJ. NO.	00125		