

THIS DRAWING AND ALL INFORMATION CONTAINED HEREIN IS THE PROPERTY OF WELDON TECHNOLOGIES, INC. AND MAY NOT BE COPIED, REPRODUCED, OR DIVULGED TO UNAUTHORIZED PERSONS WITHOUT THE EXPRESS WRITTEN CONSENT OF WELDON TECHNOLOGIES, INC. AS IT IS BEING PROVIDED SOLELY FOR THE CONVENIENCE OF THE USER AND SHALL BE RETURNED TO WELDON TECHNOLOGIES, INC UPON REQUEST.

REVISIONS				
REV.	ECN	DESCRIPTION	DATE	BY APVD
A	R0340	RELEASE FOR PRODUCTION	2/21/02	TB ST
B	R0525	ADDED -30, -40 AND -70 ASSEMBLIES	8/10/04	TS ST

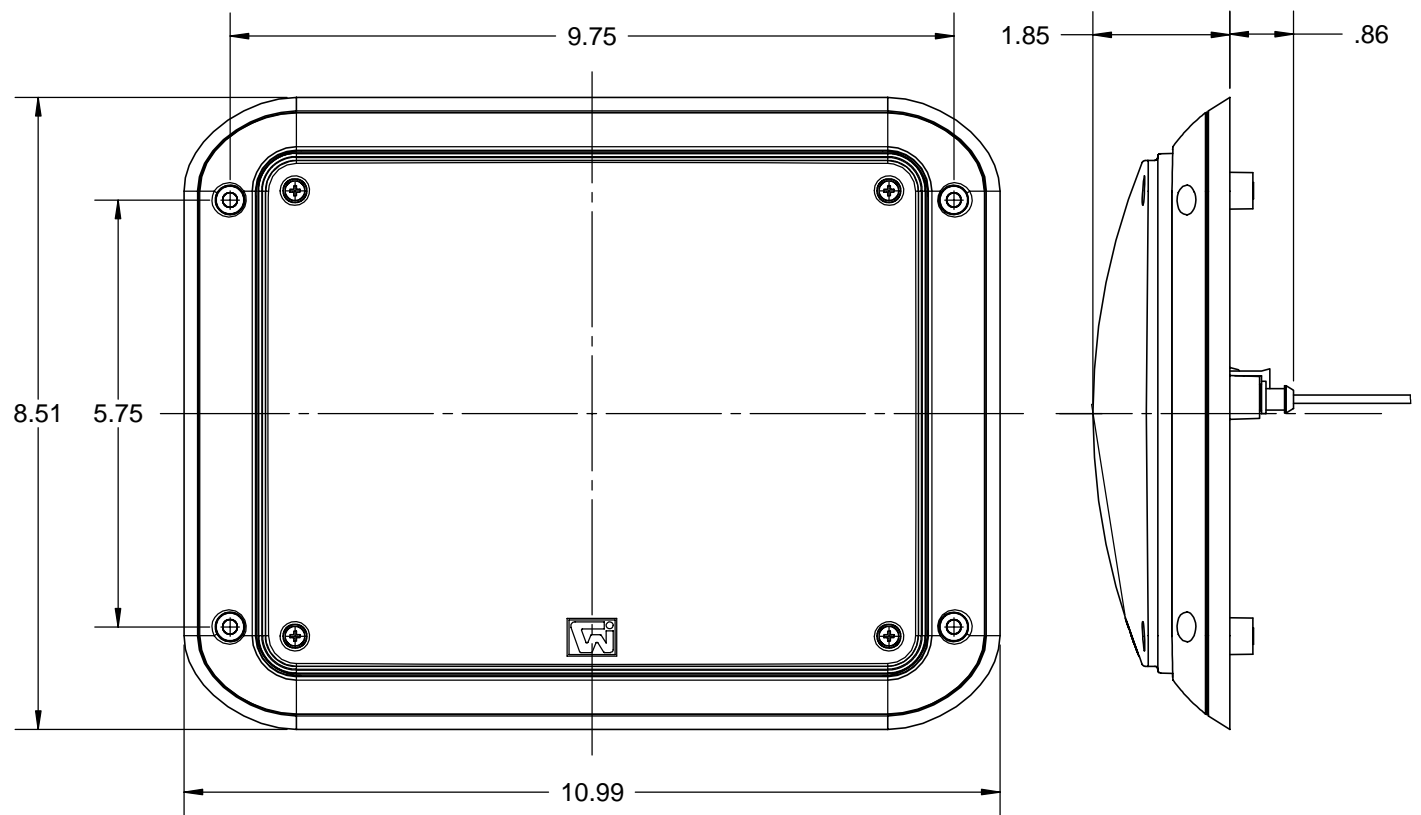
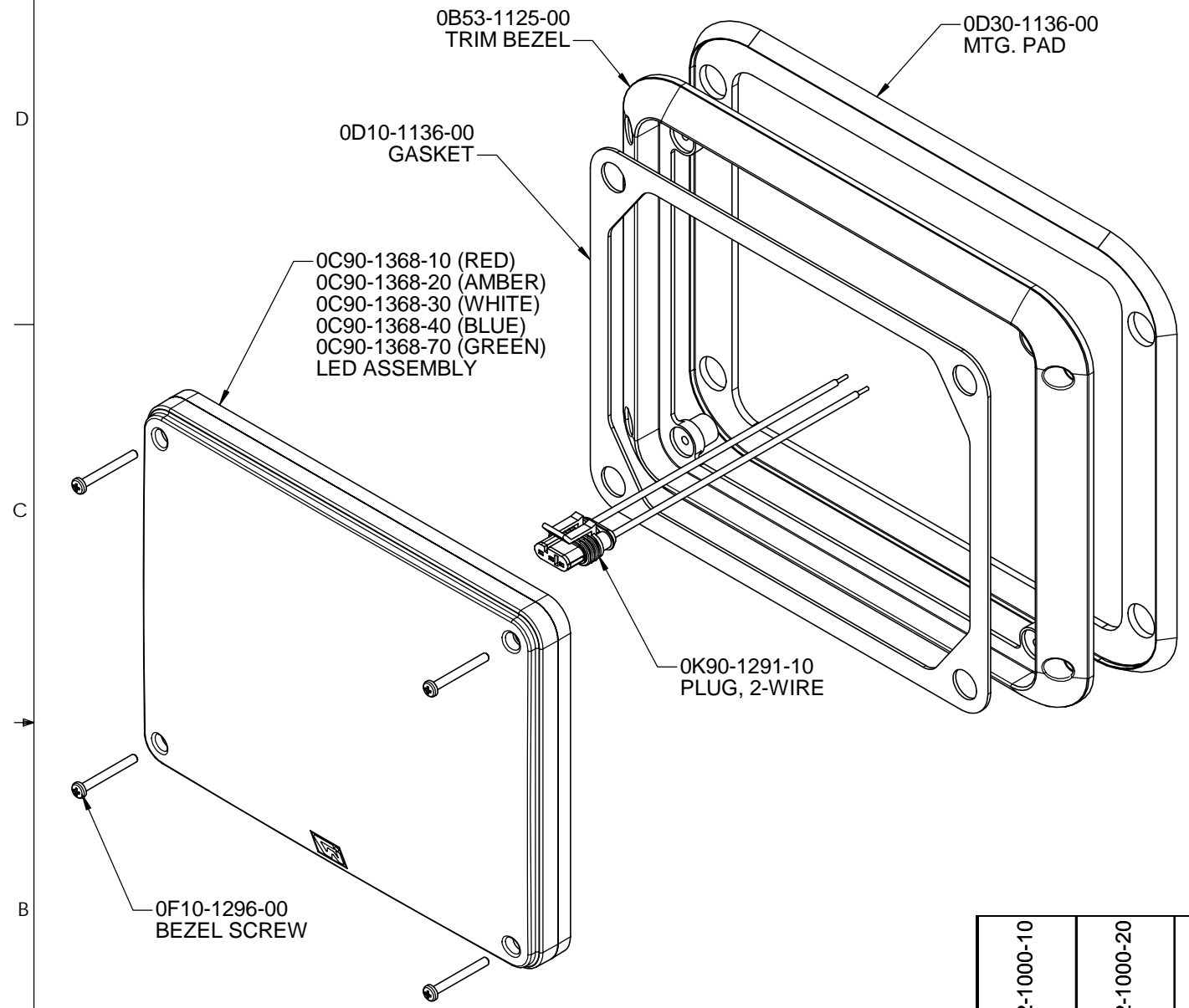

- NOTES:**
- THIS LAMP ASSEMBLY IS TO COMPLY WITH THE FOLLOWING REQUIREMENTS WHEN COUPLED WITH THE APPROPRIATE FLASHER:
 - NFPA 1901, SECTION 9-8
 - GSA-KKK-A-1822 REVISION "E"
 - LENS AND BEZEL MOUNTING HARDWARE IS INCLUDED WITH THE LAMP. USE OF HARDWARE OTHER THAN THAT SUPPLIED MAY VOID THE PRODUCT WARRANTY.
 - LAMP MUST BE MOUNTED TO A FLAT, VERTICAL SURFACE FOR PROPER SEALING AND PHOTOMETRIC PERFORMANCE.
 - LAMP MODEL NUMBERS:
 - 7872-1000-10: RED WARNING
 - 7872-1000-20: AMBER WARNING
 - 7872-1000-30: WHITE WARNING
 - 7872-1000-40: BLUE WARNING
 - 7872-1000-70: GREEN WARNING

- SPECIFICATIONS:**
- INPUT VOLTAGE RANGE: 9-32VDC
 - RED WIRE: +BATT CONNECTION, WHITE WIRE: GROUND.
 - OPERATING TEMP: -40 TO +55C
 - LENS MATERIAL IS AUTOMOTIVE GRADE POLYCARBONATE MEETING SAE WEATHERING REQUIREMENTS.
 - CURRENT DRAW:

ITEM	PART NUMBER	DESCRIPTION	7872-1000-10	7872-1000-20	7872-1000-30	7872-1000-40	7872-1000-70
1	0C90-1368-10	L.E.D. ASSEMBLY, RED	1	--	--	--	--
1	0C90-1368-20	L.E.D. ASSEMBLY, AMBER	--	1	--	--	--
1	0C90-1368-30	L.E.D. ASSEMBLY, WHITE	--	--	1	--	--
1	0C90-1368-40	L.E.D. ASSEMBLY, BLUE	--	--	--	1	--
1	0C90-1368-70	L.E.D. ASSEMBLY, GREEN	--	--	--	--	1
2	0B53-1125-00	BEZEL, CHROME PLATED	1	1	1	1	1
3	0D10-1135-00	GASKET	1	1	1	1	1
4	0K90-1291-10	PLUG, 2 WIRE	1	1	1	1	1
5	0D30-1136-00	MOUNTING PAD	1	1	1	1	1
6	0F10-1296-00	BEZEL SCREW	4	4	4	4	4
7	0F29-0329-00	PILL, MOUNTING SCREW	1	1	1	1	1
8	0P50-1350-00	POLYBAG	1	1	1	1	1
9	0P00-1346-00	CARTON	1/6	1/6	1/6	1/6	1/6
10	0P30-1347-00	DIVIDER, 6 CELL	1/6	1/6	1/6	1/6	1/6

UNLESS OTHERWISE SPECIFIED DIMENSIONS ARE IN INCHES TOLERANCES ARE: X.XXX - ±0.005 X.XX - ±0.020 X.X - ±0.050 ANGLES - ±0.5°	CAD GENERATED DRAWING, DO NOT MANUALLY UPDATE		WELDON TECHNOLOGIES, INC.	
	APPROVALS DRAWN BARNETT	DATE 2/21/02		
MATERIAL	CHECKED ST	3/4/02	CUSTOMER DRAWING L.E.D. WARNING LAMP BEZEL MOUNT 7800 SERIES	
FINISH	QUAL ENG			
DO NOT SCALE DRAWING	FILE LOCATION: \\CAD.LIB\DWG.LIB\C-DWGS\	PROJ. NO. 00117-2	SIZE B	PART NO. C7872-1000-00
	SCALE: 1:1	WELDON COMPUTER GRAPHICS	SHEET 1 OF 1	