

THIS DRAWING AND ALL INFORMATION CONTAINED HEREIN IS THE PROPERTY OF WELDON TECHNOLOGIES, INC. AND MAY NOT BE COPIED, REPRODUCED, OR DEVULGED TO UNAUTHORIZED PERSONS WITHOUT THE EXPRESS WRITTEN CONSENT OF WELDON TECHNOLOGIES, INC. AS IT IS BEING PROVIDED SOLELY FOR THE CONVENIENCE OF THE USER AND SHALL BE RETURNED TO WELDON TECHNOLOGIES, INC UPON REQUEST.

REVISIONS				
REV.	ECN	DESCRIPTION	DATE	BY / APVD
1	--	RELEASE FOR REFERENCE	2/15/01	TB

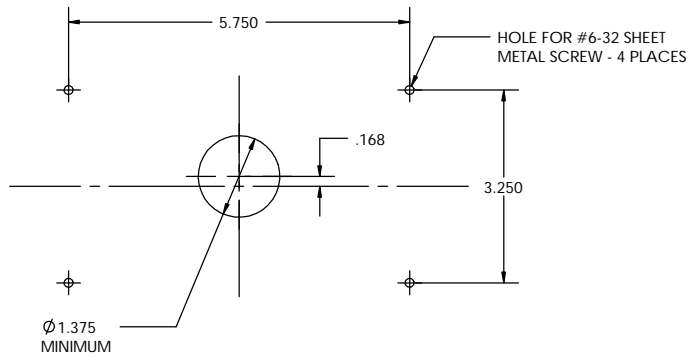
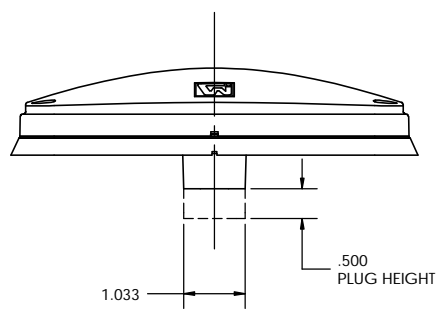
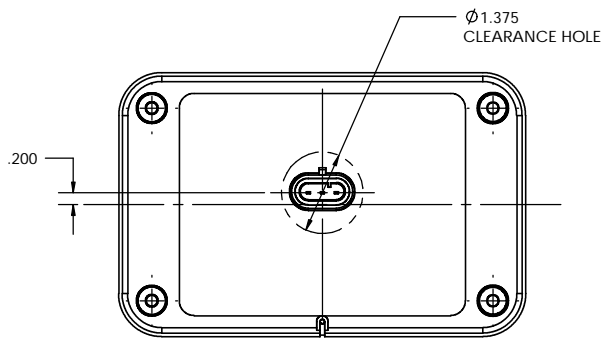
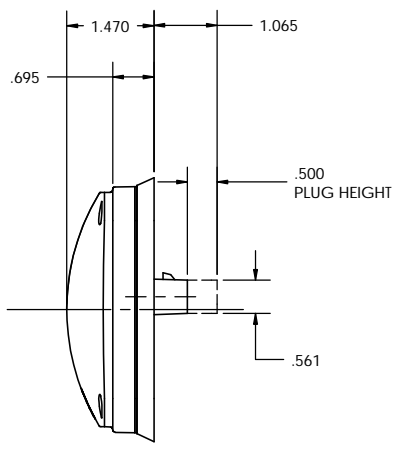
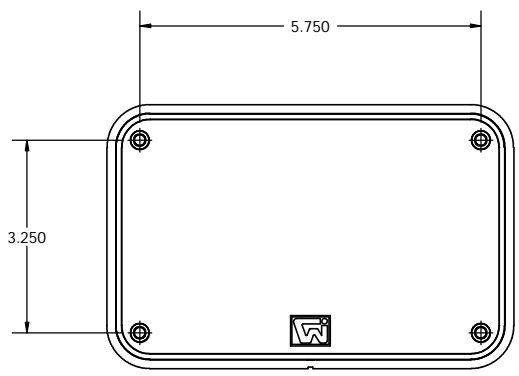

RECOMMENDED PANEL CUT-OUT

UNLESS OTHERWISE SPECIFIED DIMENSIONS ARE IN INCHES TOLERANCES ARE: X.XXX - ±0.005 X.XX - ±0.020 X.X - ±0.050 ANGLES - ±0.5°	CAD GENERATED DRAWING. DO NOT MANUALLY UPDATE		WELDON TECHNOLOGIES, INC.	
	APPROVALS	DATE	4670 SERIES PANEL MOUNT 4671 SERIES	
	DRAWN BARNETT	2/15/01		
	CHECKED			
MATERIAL	QUAL ENG			
FINISH	MFG ENG			
DO NOT SCALE DRAWING	PROJ. NO.	00117	SIZE B	REV.
			SCALE: 1:2	WELDON COMPUTER GRAPHICS SHEET 1 OF 1