

THIS DRAWING AND ALL INFORMATION CONTAINED HEREIN IS THE PROPERTY OF WELDON TECHNOLOGIES, INC. AND MAY NOT BE COPIED, REPRODUCED, OR DEVULGED TO UNAUTHORIZED PERSONS WITHOUT THE EXPRESS WRITTEN CONSENT OF WELDON TECHNOLOGIES, INC. AS IT IS BEING PROVIDED SOLELY FOR THE CONVENIENCE OF THE USER AND SHALL BE RETURNED TO WELDON TECHNOLOGIES, INC UPON REQUEST.

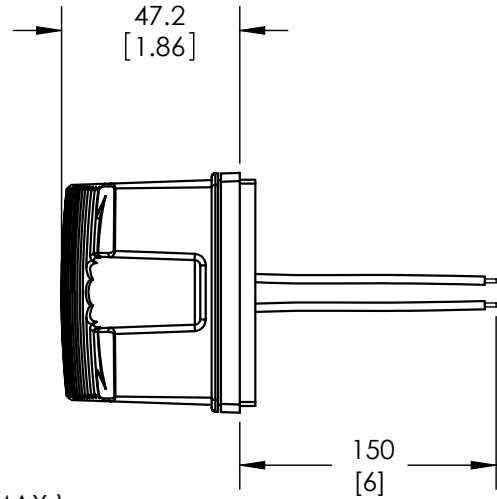
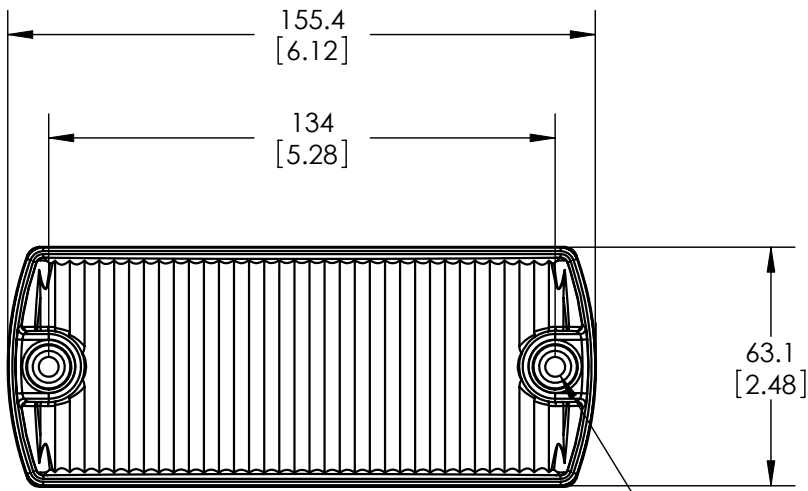

CLEARANCE HOLE FOR #10 SCREW (MAX.) 2 PLACES

NOTES:

1. LAMP IS OF SEALED CONSTRUCTION AND HAS NO SERVICEABLE COMPONENTS.
2. 32CP, 2.1A @ 12.8VDC
3. USE ON 12VDC VEHICLE SYSTEMS.
4. LAMP HAS ISOLATED GROUND

A	0763	----	RELEASE AS A REFERENCE	LH	--
REV NO.	ECO NO.	DATE	DESCRIPTION	REV BY	CKD BY
PARTS LIST					
UNLESS OTHERWISE SPECIFIED DIMENSIONS ARE SHOWN IN:		CAD GENERATED DRAWING, DO NOT MANUALLY UPDATE		Weldon Technologies, Inc. UTILITY LAMP INCANDESCENT, CLEAR	
MILLIMETERS [INCHES]		APPROVALS	DATE		
MATERIAL		DRAWN LH	6/13/07		
FINISH		CHECKED --	--		
DO NOT SCALE DRAWING		FILE LOCATION		SIZE A	DWG. NO. C2630-0000-30
		PROJECT NO.		SCALE:	WELDON COMPUTER GRAPHICS SHEET OF