

THIS DRAWING AND ALL INFORMATION CONTAINED HEREIN IS THE PROPERTY OF WELDON TECHNOLOGIES, INC. AND MAY NOT BE COPIED, REPRODUCED, OR DIVULGED TO UNAUTHORIZED PERSONS WITHOUT THE EXPRESS WRITTEN CONSENT OF WELDON TECHNOLOGIES, INC. AS IT IS BEING PROVIDED SOLELY FOR THE CONVENIENCE OF THE USER AND SHALL BE RETURNED TO WELDON TECHNOLOGIES, INC. UPON REQUEST.

REVISIONS				
REV.	ECN	DESCRIPTION	DATE	BY / APVD
A	R0808	PRODUCTION RELEASE	1/11/08	LH / ST

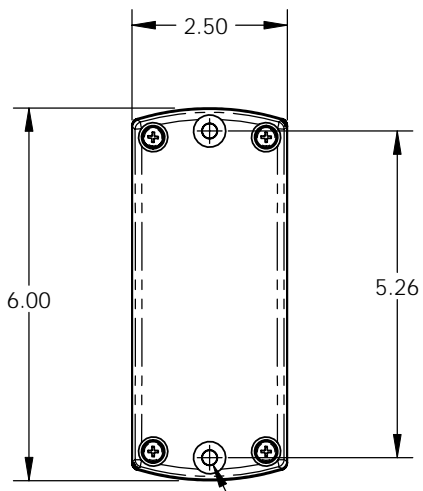

CLEARANCE FOR #10 SCREW (MAX.) (2 PLCS.)

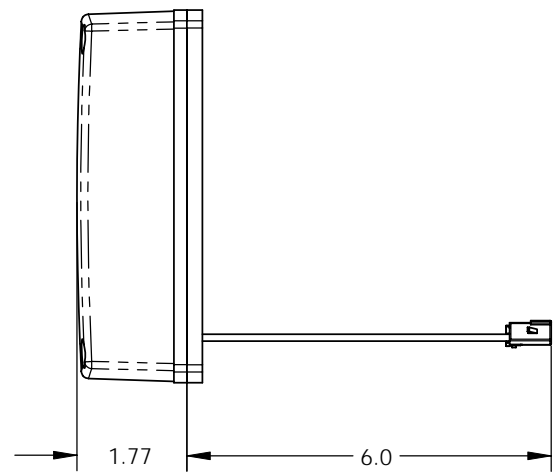

FUNCTION	WIRE COLOR	PACKARD POSITION	INCANDESCENT BULB TYPE
STOP	BLACK	A	1156
GROUND	WHITE	B	

NOTE:
MATING HARNESS CONNECTOR IS PACKARD #12047663. TERMINALS AND SEALS SHOULD BE CHOSEN BASED ON WIRE GAUGE AND INSULATION DIAMETER

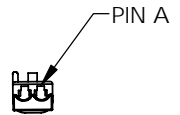

CONNECTOR VIEW
INSERTION END

UNLESS OTHERWISE SPECIFIED DIMENSIONS ARE IN INCHES TOLERANCES ARE: X.XXX - ±0.005 X.XX - ±0.020 X.X - ±0.050 ANGLES - ±0.5°	CAD GENERATED DRAWING. DO NOT MANUALLY UPDATE		WELDON TECHNOLOGIES, INC.		
	APPROVALS	DATE			
	DRAWN	LH	12/14/07	BACK-UP LAMP, VERTICAL CLEAR, FLAT BLACK W/PACKARD TERMINAL	
	CHECKED				
MATERIAL	QUAL ENG				
FINISH	MFG ENG		SIZE B	PART NO. C2025-7100-31	REV. A
DO NOT SCALE DRAWING	PROJ. NO.		SCALE: 1:1	WELDON COMPUTER GRAPHICS SHEET 1 OF 1	