

THIS DRAWING AND ALL INFORMATION CONTAINED HEREIN IS THE PROPERTY OF WELDON TECHNOLOGIES, INC. AND MAY NOT BE COPIED, REPRODUCED, OR DEVULGED TO UNAUTHORIZED PERSONS WITHOUT THE EXPRESS WRITTEN CONSENT OF WELDON TECHNOLOGIES, INC. AS IT IS BEING PROVIDED SOLELY FOR THE CONVENIENCE OF THE USER AND SHALL BE RETURNED TO WELDON TECHNOLOGIES, INC. UPON REQUEST.

REVISIONS					
REV.	ECN	DESCRIPTION	DATE	BY	APVD
A	R0822	DOCUMENTATION RELEASE	5/9/08	TB	ST

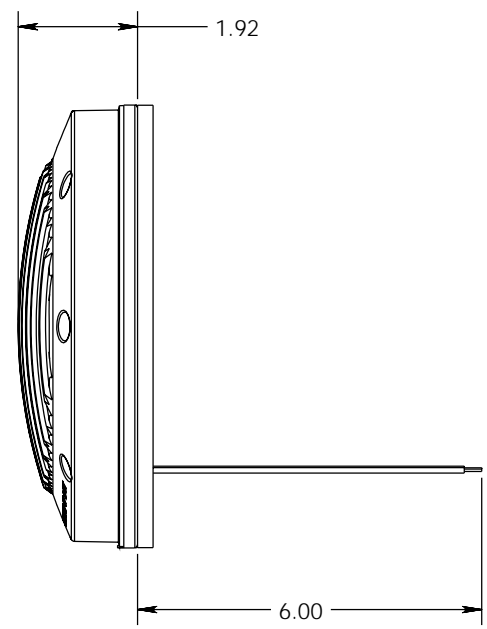
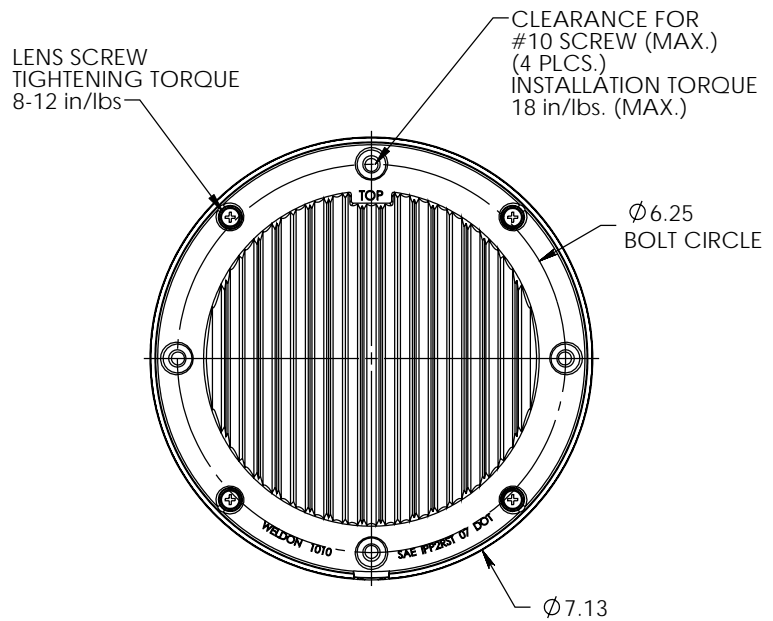

Service Part Number	Description	Qty.
1003-1000-30	Lens, Acrylic, Clear	1
1014-0000-00	Gasket, Lens	1
1015-0000-00	Gasket, Mounting	1
9018-0019-00	Bulb, Miniature, #1141, 21cp	1
9028-0006-00	Screw, Lens, 8-32 x 7/16 PPHMS, TT	4

1013-7100-30

UNLESS OTHERWISE SPECIFIED DIMENSIONS ARE IN INCHES TOLERANCES ARE:		CAD GENERATED DRAWING. DO NOT MANUALLY UPDATE		WELDON TECHNOLOGIES, INC.	
X.XXX - ±0.005 X.XX - ±0.020 X.X - ±0.050 ANGLES - ±0.5°		APPROVALS			
MATERIAL		DRAWN	TB	5/1/08	
FINISH		CHECKED	ST	5/3/08	
DO NOT SCALE DRAWING		PROJ. NO.		SCALE: 1:1	
PART NO. C1013-7100-00		REV. A		SHEET 1 OF 1	

CUSTOMER DRAWING
7" ROUND, D.O.T.
FLAT BACK