



Style 9293

**Roof Turret Valve Inlet
Update Kit (with Brass
Inlet Elbow) for:**

3367 and 3467 Type V Base

Turret valve / inlet upgrade kit parts list

1	3	123564	Brass inlet elbow
1	37	742232	Seal plate, stainless steel
2	259	761100	Hex head cap screw 3/8-16 x 2"
6	55	761058	Hex head cap screw 3/8-16 x 1 1/2"
2	Not shown	769181	Valve Seat, 3" valve
1	36	757377	O-Ring
1	Not shown	729732	Loctite 518 kit for seal plate
2	Not shown	729733	Loctite 243 kit for adapter bolts

Installation instructions for Turret valve / inlet upgrade kit

Dissassembly:

1. Remove existing valve inlet elbow (#3):

- a. From the outside, remove the four 3/8" socket head cap screws (#130) that hold the inlet elbow to the turret base plate (#179). It may also be necessary to score around the inlet elbow where it meets the turret baseplate using a razor knife to separate the sealant between the two pieces.
- b. Inside the vehicle, remove the headliner from the turret frame (1/4 turn fasteners around the edge of the headliner).
- c. Open the turret valve to allow any trapped water to empty through the drain fitting.
- d. Remove the valve override handle from the valve and pneumatic cylinder.
- e. The inlet elbow may have a pressure gauge pickup line attached at location #303, remove the line if installed. If no pressure line is installed, remove the pipe plug and save for installation in new brass inlet elbow.
- f. Remove the oscillation adjustment assembly (if present) from the bottom of the valve by removing the four screws and washers that attach the assembly to brackets (#111). The assembly wiring can remain connected, just move the assembly to the side. (A toggle switch assembly is sometimes attached to the oscillation adjustment assembly, if so, remove it with the oscillation adjustment assembly)
- g. If the toggle switch assembly was not attached to the oscillation adjustment assembly, it will be attached to the turret frame below the inlet elbow. Remove the assembly and move aside leaving the wiring and air tubing attached to make room for the inlet elbow to slide out.
- h. Remove the four valve adapter hex head cap screws (#55) from the inlet side of the valve. This will allow the inlet to be removed from the turret. You may have to use a flat screw driver or other prying tool between the inlet elbow and the inside surface of the turret frame to help loosen the inlet elbow. The neoprene gasket (36) should also be removed with the elbow.
- i. There will also be a black neoprene gasket between the valve and inlet elbow. This can be removed and discarded.

2. Remove the Valve assembly:

- a. At this point, there should only be four adapter hex head cap screws (2- #55 at the top and 2-#259 on the bottom) holding the valve assembly to the turret assembly. While supporting the valve assembly, remove these four remaining hex head cap screws and remove the valve assembly from the turret.
- b. There are two black neoprene gaskets (one on each side of the valve assembly) these can be removed and discarded.

3. Inspect and Service the Valve Assembly:

- a. This retrofit kit includes new valve seats. With the valve ball in the partially open position, the valve seats can be removed by grabbing the lip of the seat in the open space between the valve ball and seat and pulling outward.
- b. Inspect the valve ball for damage. If the ball needs to be replaced, you can order valve repair kit 9194 which comes with the valve ball and all o-rings needed to refurbish the valve assembly.
- c. The new seats are installed by simply pushing them into the valve body until fully seated.

Re-Assembly:

1. Installing new seal plate:

a. Required Tools/adhesives:

- 1) 1" diameter High Density Foam Roller
- 2) Loctite ODC Free Cleaner and Degreaser
- 3) Loctite 518
- 4) Primer N

b. Procedure:

- 1) The Stainless Steel Seal Plate (#37) has a protective sheet on the side that mates with the Valve Seat. Remove protective sheet and remove any residue on the seal plate.
- 2) The opposite side of the Seal Plate, which may have imperfections on the surface, will be mated with the aluminum turret inlet elbow. Clean this side of the Seal Plate and apply Primer 'N'. (Caution: Primer 'N' attacks the turret mounting plate foam insulation. The foam insulation around the valve should be covered during this process and any spills cleaned up immediately.) Allow to dry a minimum of two minutes.
- 3) Clean the flange on the aluminum turret Inlet Elbow and allow it to dry.
- 4) Apply Loctite 518 to the flange face of the aluminum turret Inlet Elbow.
- 5) Use the Foam Roller to spread an even coat on the surface. A light coating is sufficient as long as the entire surface is covered with Loctite.
- 6) The amount of time to assemble the valve body and seal plate to the aluminum turret Inlet Elbow is flexible. However, once the Loctite 518 comes into contact with the Primer 'N' the flange bolts (#55 and #259) should be tightened as quickly as possible. Loctite 243 should be used on these flange bolts. Progressively tighten the bolts in a cross pattern. Torque bolts between 38-40 foot-lbs.

2. Installing Brass valve Inlet elbow:

- a. Place the new neoprene gasket (#36) over the Victaulic end of the new brass inlet elbow (#3).
- b. Push the Victaulic end of the inlet elbow through the opening in the turret mounting plate from inside the truck cab.
- c. Using Loctite 243, install the four hex head cap screws (#55) that connect the brass inlet elbow to the brass valve body and hand tighten.
- d. From the top of the cab, install the four socket head cap screws (#130) that hold brass inlet elbow to the turret mounting plate using Loctite 243 and hand tighten.
- e. Progressively tighten the valve adapter bolts (#55) in a cross pattern. Torque bolts between 38-40 foot-lbs
- f. Progressively tighten the valve inlet socket head cap screws (#130) in a cross pattern. Torque between 25-30 foot-lbs.
- g. A urethane sealant (Sikaflex 1a or equivalent) should be used to seal the area between the brass inlet elbow and the top of the turret mounting plate.
- h. Install the pipe plug (or pressure gauge hose) from the old inlet elbow into the new elbow using Teflon tape or other appropriate thread sealant.

Figure 1

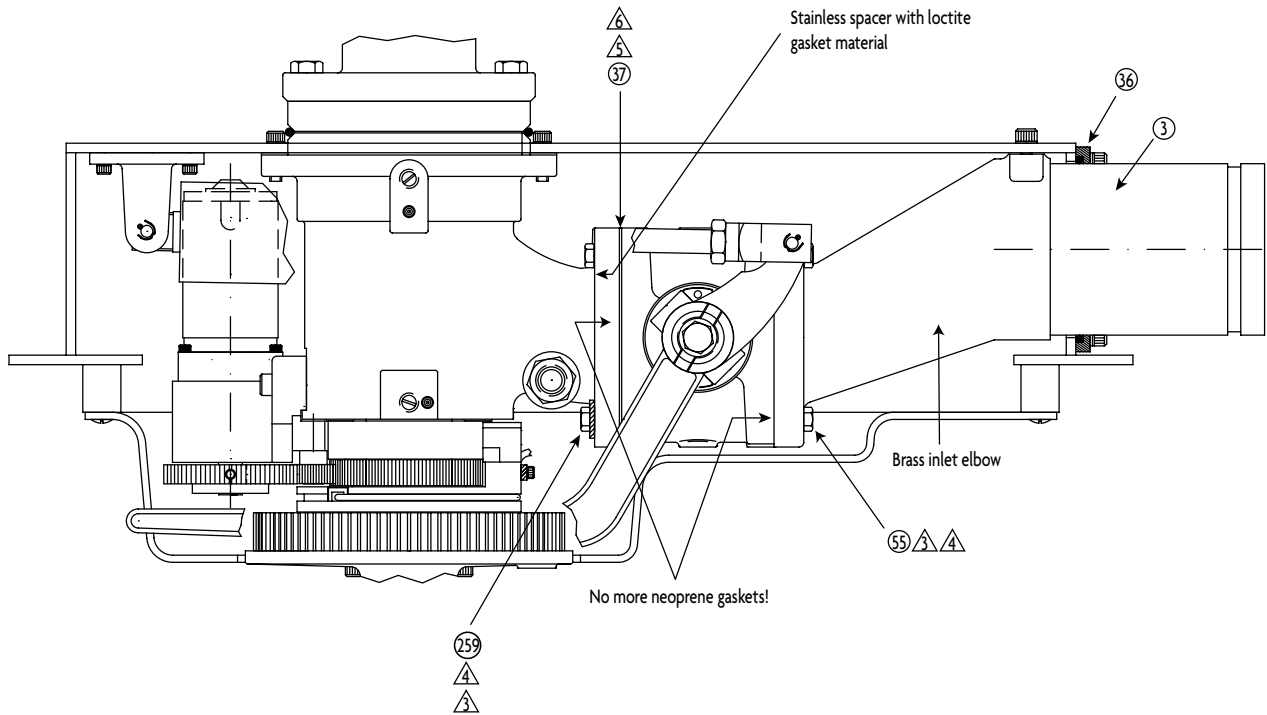

Assembly Notes

- ▲ USE PERMABOND LM113 OR LOCTITE #222
- ▲ TORQUE FLANGE BOLTS 38-40 FT LBS
- ①▲ USE PRIMER N AND LOCTITE 518 TO SIDE OF PLATE OPPOSITE TO SIDE WITH PROTECTIVE SHEET
- ▲ SIDE WITH PROTECTIVE SHEET FACES VALVE SEAT. REMOVE PROTECTIVE SHEET AT ASSEMBLY



PHONE: 330.264.5678 or 800.228.1161 | FAX: 330.264.2944 or 800.531.7335 | akronbrass.com

REVISED: 11/17

WARRANTY AND DISCLAIMER: We warrant Akron Brass products for a period of five (5) years after purchase against defects in materials or workmanship. Akron Brass will repair or replace product which fails to satisfy this warranty. Repair or replacement shall be at the discretion of Akron Brass. Products must be promptly returned to Akron Brass for warranty service.

We will not be responsible for: wear and tear; any improper installation, use, maintenance or storage; negligence of the owner or user; repair or modification after delivery; damage; failure to follow our instructions or recommendations; or anything else beyond our control. WE MAKE NO WARRANTIES, EXPRESS OR IMPLIED, OTHER THAN THOSE INCLUDED IN THIS WARRANTY STATEMENT, AND WE DISCLAIM ANY IMPLIED WARRANTY OF MERCHANTABILITY OR FITNESS FOR ANY PARTICULAR PURPOSE. Further, we will not be responsible for any consequential, incidental or indirect damages (including, but not limited to, any loss of profits) from any cause whatsoever. No person has authority to change this warranty.

© Akron Brass Company, 2017 All rights reserved. No portion of this can be reproduced without the express written consent of Akron Brass Company.