



AKRON[®]
BRASS COMPANY

**INSTRUCTION MANUAL
AND PARTS LIST**

**WATER FLOW TEST KIT
STYLE 9015**



OPERATION

1. Determine criteria for your testing from NFPA or ISO publications, or other authority.
2. Connect Test Kit swivel inlet to hydrant or other fixed 2 1/2" discharge device. (For best results, the test kit should be preceded by minimum 3 foot long straight, open 2 1/2" waterway.)
3. Loosen thumbscrews and rotate pitot blade out of stream position.
4. Select from the Discharge Table, the preferred tip diameter for the expected flow. Install the tip as follows:
 - a. Unscrew lock ring.
 - b. Pull out gray tip. (Caution: do not use tools which may damage waterway).
 - c. Insert proper size tip completely until retaining ring is snug against nozzle body.
 - d. Screw on lock ring clockwise until tight.

CAUTION:
***FAILURE TO REPLACE LOCK RING MAY ALLOW TIP TO
BLOW OUT, CAUSING DAMAGE OR INJURY.***

- 5a. Hydrant: Open hydrant and flush rocks, etc. Rotate blade back into center of stream and tighten thumbscrew. Record pressure reading.
- 5b. Pumper: After warm-up, bring pump up to desired speed and close throttling valve(s) to set discharge pressure at required rating. Rotate pitot blade into stream center and tighten thumbscrew. Record pressure reading.
6. When hydrant or pumper must continue to operate (e.g. endurance test), rotate blade out of stream between readings to reduce wear and avoid damage.
7. Read flow at intersection of tip size and pressure in Table. DO NOT apply additional hydrant coefficients since the nozzle tip replaces the hydrant outlet as the orifice.
8. After use, open bleeder valve and drain any water in the pitot air chamber. Draining is especially important in freezing weather.

Parts List

ITEM NO.	DESCRIPTION	PART NUMBER	QUANTITY
1	3/4"/19mm tip	9015-0015	1
1	15/16"/23.8mm tip*	9015-0016	1
1	1"/25mm tip*	9015-0017	1
1	1 1/8"/28.5mm tip	9015-0018	1
1	1 1/4"/31.8mm tip*	9015-0019	1
1	1 1/2"/38.1mm tip	9015-0020	1
1	1 3/4"/44.5mm tip	9015-0021	1
1	1 7/8"/47.6mm tip*	9015-0024	1
1	2"/50.8mm tip	9015-0022	1
1	2 1/4"/57.2mm tip	9015-0023	1
2	Body	110283	1
3	Set Screw	7-42-023	1
4	2 1/2" Inlet Swivel (NH) **	101420	1
5	Gasket	7-17-043	1
6	Ball Bearings	††	39
7	Bleeder Valve	7-79-045	1
8	Thumb Screw	7-67-110	1
9	Pitot Adapter Tube	110098	1
10	Stop Screw	7-67-111	1
11	Pressure Gauge - PSI/kPa	7-18-183	1
12	Quick Connect - 1/4" Socket	7-07-169	1
13	Quick Connect - 1/4" Plug	7-07-170	1
14†	O-Ring	7-57-022	1
15†	Set Screw (cup point)	7-65-024	1
16†	Pitot Blade	110087	1
17	Retaining Ring	7-56-089	1
18	Lock Ring	109227	1
19	O-Ring	7-57-239	1
20†	Set Screw (dog point)	7-65-117	1
21	O-Ring	7-57-052	1
22	Label	7-73-247	1
-	Carry Case w/Liner	7-07-311	1
-	Instruction Manual	7-04-607	1
-	Laminated Discharge Table	7-07-328	1

NOTE: When ordering replacement tips check retaining ring (#17) and O-Ring (#19)

** For other threads order by description and thread size (ODM and TPI) or by Akron Thread Code.

†† Package of 50 Ball Bearings - P/N 109041.

† Parts included in Pitot Blade Replacement Kit - P/N 110086. Kit includes reusable Alignment Fixture - P/N 7-12-269

* Tips not part of standard unit. Only tips in standard units are U.L. Classified.

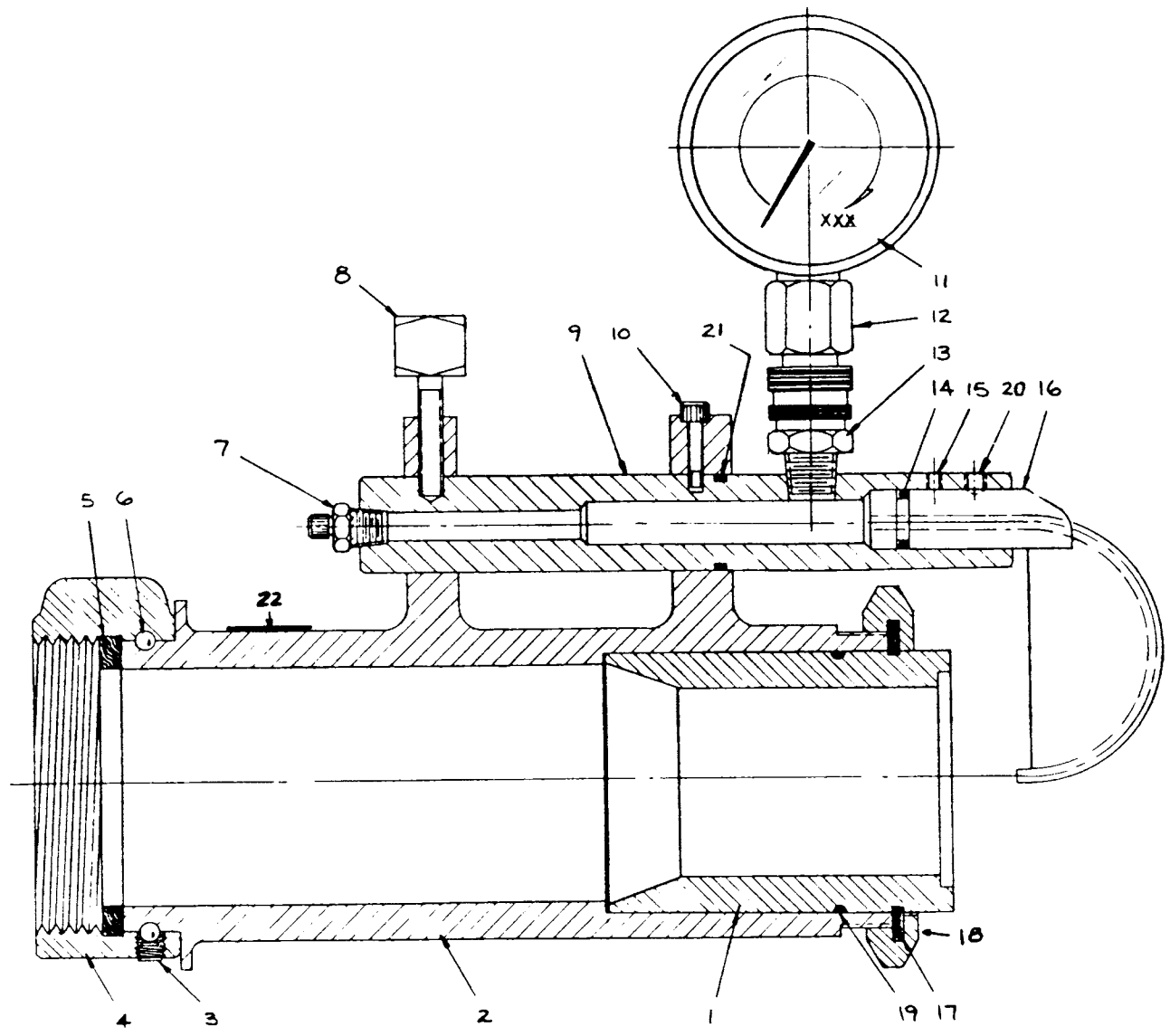

MAINTENANCE

Maintenance requirements will vary widely depending on conditions and amount of service.

1. Lubricate seals, bearing surfaces and swivel occasionally with light machine oil or spray lubricant.
2. Check pitot gauge against a test gauge regularly.

REPAIR

PROBLEM

1. Pitot blade or tip damaged.
2. Leak around lock ring.
3. Leak thru bleeder valve.
4. No reading on pressure gauge.

ACTION

1. Replace. Instructions and alignment fixture provided with replacement blades.
2. Replace tip O-Ring.
3. Replace O-Ring.
4. Check for obstruction in Pitot Blade waterway.
Clean coupling and gauge stem. Replace gauge if necessary.

SUGGESTED NOZZLE TIP SIZE TYPICAL PUMPER TESTS* (GPM)

	NET PUMP PRESSURE	NOZZLE TIP SIZE	PITOT PRESSURE PSI	GPM
500 GPM PUMPER				
100% rated capacity	150	1 1/2"	58	508
70% rated capacity	200	1 1/8"	88	351
50% rated capacity	250	1 1/8"	46	254
700 GPM PUMPER				
100% rated capacity	150	1 3/4"	68	750
70% rated capacity	200	1 1/2"	62	525
50% rated capacity	250	1 1/8"	100	374
1000 GPM PUMPER				
100% rated capacity	150	2"	71	1002
70% rated capacity	200	1 3/4"	60	704
50% rated capacity	250	1 1/2"	58	508
1250 GPM PUMPER				
100% rated capacity	150	2 1/4"	69	1251
70% rated capacity	200	2"	55	882
50% rated capacity	250	1 1/2"	90	633
1500 GPM PUMPER				
100% rated capacity	150	2 1/4"	100	1506
70% rated capacity	200	2"	78	1050
50% rated capacity	250	1 3/4"	68	750
1750 GPM PUMPER				
100% rated capacity	150	2" 2 lines	55	882 ea.
100% rated capacity	150	1 3/4" 2 lines	94	881 ea.
70% rated capacity	200	2 1/4"	66	1224
50% rated capacity	250	2"	55	882
2000 GPM PUMPER				
100% rated capacity	150	2" 2 lines	71	1002 ea.
70% rated capacity	200	1 3/4" 2 lines	60	704 ea.
70% rated capacity	200	2 1/4"	87	1402
50% rated capacity	250	2"	71	1002

* Based on Test Requirements "UL 822 Certification of Fire Department Pumps"
Underwriters Laboratories, Inc., Northbrook, IL.

Figures represented on the Discharge Table are accurate to +/-3% at tested values in accordance with the classification scope.

SUGGESTED NOZZLE TIP SIZE TYPICAL PUMPER TESTS* (LPM)

	NET PUMP PRESSURE	NOZZLE TIP SIZE-MM	PITOT PRESSURE KPA	GPM
2000 LPM PUMPER				
100% rated capacity	1000	38.1	440	2018
70% rated capacity	1350	28.5	680	1401
50% rated capacity	1700	28.5	350	1003
3000 LPM PUMPER				
100% rated capacity	1000	50.8	320	3051
70% rated capacity	1350	38.1	480	2112
50% rated capacity	1700	28.5	790	1518
4000 LPM PUMPER				
100% rated capacity	1000	50.8	550	4024
70% rated capacity	1350	44.5	470	2839
50% rated capacity	1700	38.1	440	2018
5000 LPM PUMPER				
100% rated capacity	1000	57.2	540	5035
70% rated capacity	1350	50.8	430	3543
50% rated capacity	1700	38.1	690	2525
6000 LPM PUMPER				
100% rated capacity	1000	57.2	790	6113
70% rated capacity	1350	50.8	610	4221
50% rated capacity	1700	44.5	540	3040
7000 LPM PUMPER				
100% rated capacity	1000	50.8 2 lines	430	3543
100% rated capacity	1350	44.5 2 lines	730	3528
70% rated capacity	1350	57.2	510	4906
50% rated capacity	1700	50.8	430	3543
8000 LPM PUMPER				
100% rated capacity	1000	50.8 2 lines	550	4024
70% rated capacity	1350	44.5 2 lines	730	3528
70% rated capacity	1350	57.2	680	5644
50% rated capacity	1700	50.8	550	4024

* Based on Test Requirements "ULC-822 Guide for Listing and Labeling of Fire Department Pumpers" Underwriters Laboratories of Canada, Scarborough, Ontario, Canada

Figures represented on the Discharge Table are accurate to ±3% at tested values in accordance with the classification scope.

**WATER FLOW TEST KIT
AKRON BRASS
STYLE 9015
PRECAUTIONS**

1. Follow instructions in **NFPA 1911, Acceptance and Service Test of Fire Department Pumping Apparatus, NFPA 291 Fire Flow Testing and Marking of Hydrants or NFPA 1901 Automotive Fire Apparatus** to promote safe and valid testing.
2. Mount the test kit nozzle securely. Never attempt to use the tester “hand-held”.
3. Direct the stream toward a cleared space that will remain clear throughout the test. This precaution is especially important when testing hydrants along travelled streets and sidewalks.
4. Give the pressure gauge a “tug” after making quick connect to assure that the coupling has seated before pressurizing.
5. Use caution around the high velocity water streams and moving parts of the test kit.
6. Check all hose and apparatus connections before pressurization.
7. Do not attempt to interchange tips with stream running or pressurize a tip without lock ring secured in place.
8. Pitot blades are delicate and expensive. Replacement may require return of the entire kit for factory recalibration. Always flush hydrant or pumper before inserting blade in stream. Do not drop blades or place them where they might be stepped on.



PHONE: 330.264.5678 or 800.228.1161 | FAX: 330.264.2944 or 800.531.7335 | akronbrass.com

REVISED: 9/11

WARRANTY AND DISCLAIMER: We warrant Akron Brass products for a period of five (5) years after purchase against defects in materials or workmanship. Akron Brass will repair or replace product which fails to satisfy this warranty. Repair or replacement shall be at the discretion of Akron Brass. Products must be promptly returned to Akron Brass for warranty service.

We will not be responsible for: wear and tear; any improper installation, use, maintenance or storage; negligence of the owner or user; repair or modification after delivery; damage; failure to follow our instructions or recommendations; or anything else beyond our control. WE MAKE NO WARRANTIES, EXPRESS OR IMPLIED, OTHER THAN THOSE INCLUDED IN THIS WARRANTY STATEMENT, AND WE DISCLAIM ANY IMPLIED WARRANTY OF MERCHANTABILITY OR FITNESS FOR ANY PARTICULAR PURPOSE. Further, we will not be responsible for any consequential, incidental or indirect damages (including, but not limited to, any loss of profits) from any cause whatsoever. No person has authority to change this warranty.

© Akron Brass Company, 2011 All rights reserved. No portion of this can be reproduced without the express written consent of Akron Brass Company.