



AKRON[®]
BRASS COMPANY

**STYLE 6035 CAN PULSE-STREAM JOYSTICK
INSTALLATION, OPERATION & MAINTENANCE MANUAL**

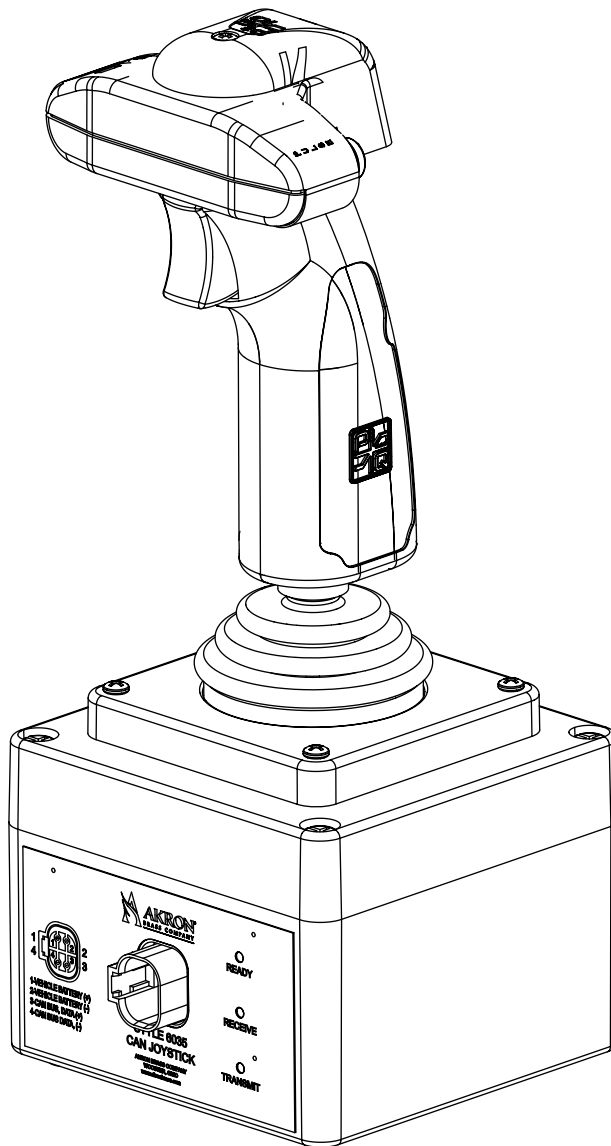

TABLE OF CONTENTS

SAFETY SUMMARY	2
PRODUCT SPECIFICATIONS	3
6035 CAN JOYSTICK.....	3
INSTALLATION INSTRUCTIONS	4
TOOLS & MATERIALS REQUIRED	4
MECHANICAL INSTALLATION.....	4
ELECTRICAL INSTALLATION.....	7
OPERATING INSTRUCTIONS	10
NORMAL OPERATION.....	10
SETUP AND CALIBRATION.....	11
Zeroing and Spanning the Joystick.....	11
Changing the Priority Level.....	11
MAINTENANCE INSTRUCTIONS	12
TROUBLESHOOTING	13
DIAGNOSTIC LEDs.....	13
AKROVIEW SOFTWARE.....	13
REVISION HISTORY	14

LIST OF ILLUSTRATIONS

Figure 1 – Surface Mounting Hole Layout.....	5
Figure 2 – Flush Mount Hole Layout.....	6
Figure 3 – Adapter Plate Hole Layout.....	6
Figure 4 – Connector Label.....	7
Figure 5 – Typical Electrical Connections.....	8
Figure 6 – Typical J1939 Wiring.....	9

SAFETY SUMMARY

SIGNAL WORD DEFINITION

Per the ANSI Z535.4 standard, the following signal words and definitions are used to indicate hazardous situations:

⚠ DANGER

DANGER indicates an imminently hazardous situation that, if not avoided, will result in death or serious injury.

⚠ WARNING

WARNING indicates a potentially hazardous situation that, if not avoided, could result in death or serious injury.

⚠ CAUTION

CAUTION indicates a potentially hazardous situation that, if not avoided, may result in minor or moderate injury. It is also used to alert against unsafe practices.

GENERAL SAFETY PRECAUTIONS

The following are general safety precautions that are not related to any specific procedures and therefore do not appear elsewhere in this publication. These are recommended precautions that personnel must understand and apply during many phases of operation and maintenance.

⚠ WARNING

For fire fighting use only by trained fire fighters.

⚠ WARNING

Do not use the Joystick when the override cranks are being used or are in position for use.

⚠ CAUTION

Although the enclosure for the Joystick is water-resistant, it is important to keep water out of the enclosure. Prolonged exposure to water will cause damage. When the cover of the enclosure is removed, make sure the seal under the cover is intact and free of dirt and debris.

⚠ CAUTION

This product must be wired in adherence with the SAE J1939/11 specification. Failure to do so may result in sporadic operation or non-operation.

⚠ CAUTION

While this device is designed to reside on a standard J1939 CAN network, it is recommended that Akron Brass CAN products operate on their own CAN network isolated from the other CAN networks on the vehicle.

PRODUCT SPECIFICATIONS

6035 CAN JOYSTICK

- Power - 8 to 33 volts DC, <.25 amperes
- Operating Temperature - -40°C. to +85°C.
- Storage Temperature - -50°C. to +85°C.
- Communications – J1939/11 CAN Network
- Proportional Control

INSTALLATION INSTRUCTIONS

TOOLS & MATERIALS REQUIRED

- Medium Phillips screwdriver • Small flat screwdriver
- Metric Allen Wrench Set
- Deutsch Crimping Tool
- Deutsch DTM06-4S-CE13 or equivalent and associated crimp terminals
- Optional Akron Brass 721579 pre-wired connector/harness

MECHANICAL INSTALLATION

The 6035 CAN Joystick comes with a mounting kit that allows either surface or flush mounting.

For a surface mount application, carefully remove the lid of the Joystick by loosening the four screws on each corner of the lid. Drop one each of the M2.5 X 20 mm cap screws head first into the four holes in the main enclosure body directly under the four small holes in the lid. Replace and reattach the lid. Using the appropriate Allen wrench, attach the flush mount bezel to the Joystick. See Figure 1 for recommended panel cutout.

For a flush mount application, three methods may be utilized. When access to the back of the mounting surface is available, use four M6 screws from behind to directly mount the Joystick to the surface. See Figure 2 for recommended hole layout.

A second flush mount method utilizes the included adapter plate. Use the included M6 flat head screws to attach the adapter plate to the bottom of the Joystick. Next, utilizing four screws of the customer's choosing, attach the Joystick to the mounting surface. See Figure 3 for recommended hole layout.

A third flush mount method is achieved by inserting four screws through the top of the lid all the way through the CAN Joystick to threaded holes located underneath in the mounting surface.

CAUTION

Although the enclosure for the Joystick is water-resistant, it is important to keep water out of the enclosure. Prolonged exposure to water will cause damage. When the cover of the enclosure is removed, make sure the seal under the cover is intact and free of dirt and debris.

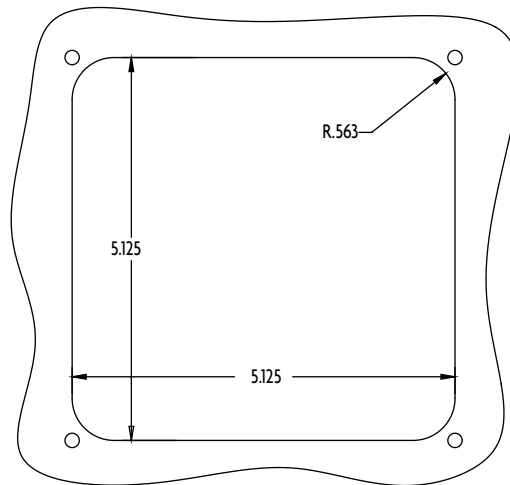

RECCOMENDED OPENING
FOR FLUSH MOUNTING
(TO SCALE)

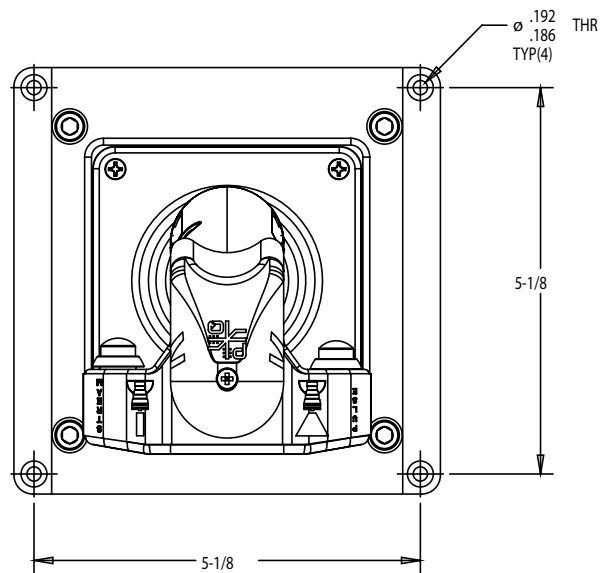

Figure 2

Flush Mount Hole Layout

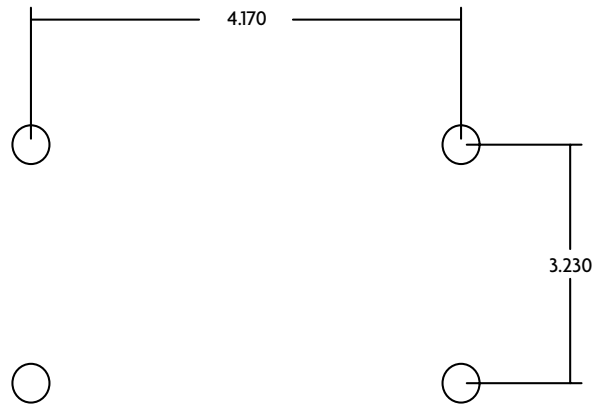
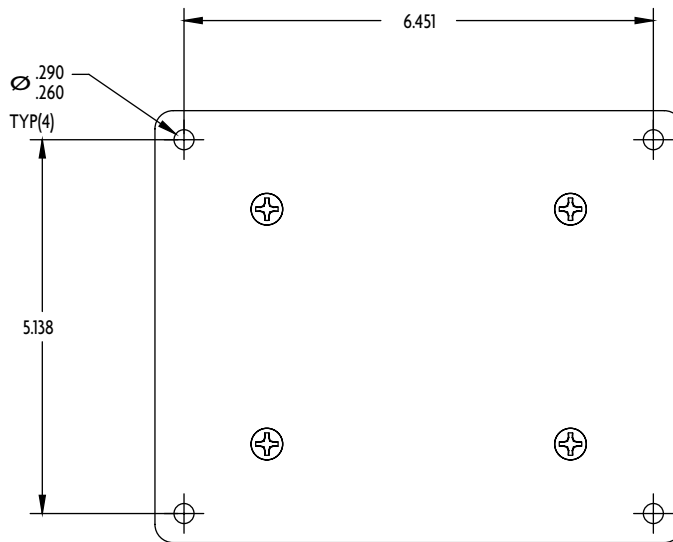

Figure 3

Adapter Plate Hole Layout



ELECTRICAL INSTALLATION

⚠ CAUTION

This product must be wired in adherence with the SAE J1939/11 specification. Failure to do so may result in sporadic operation or non-operation.

⚠ CAUTION

While this device is designed to reside on a standard J1939 CAN network, it is recommended that Akron Brass CAN products operate on their own CAN network isolated from the other CAN networks on the vehicle.

The following is intended to provide the basic instructions for installation and operation of the 6035 CAN Joystick. Refer to Figure 4, Figure 5, and Figure 6 for additional information. Wiring must be in compliance with SAE J1939 for proper operation.

- Step 1** Connect Battery Positive to Pin #1 (use of Akron Brass Harness stub part number 721579 is recommended)
- Step 2** Connect Battery Negative to Pin #2
- Step 3** Connect CAN HI to Pin #3 (Akron Brass Harness stub part number 721579 already has this pin properly connected to a J1939 CAN network stub connector)
- Step 4** Connect CAN LO to Pin #4 (Akron Brass Harness stub part number 721579 already has this pin properly connected to a J1939 CAN network stub connector)
- Step 5** Add a terminating resistor if this device is at the end of the network.

Figure 4

Connector Label



Figure 5

Typical Electrical Connections

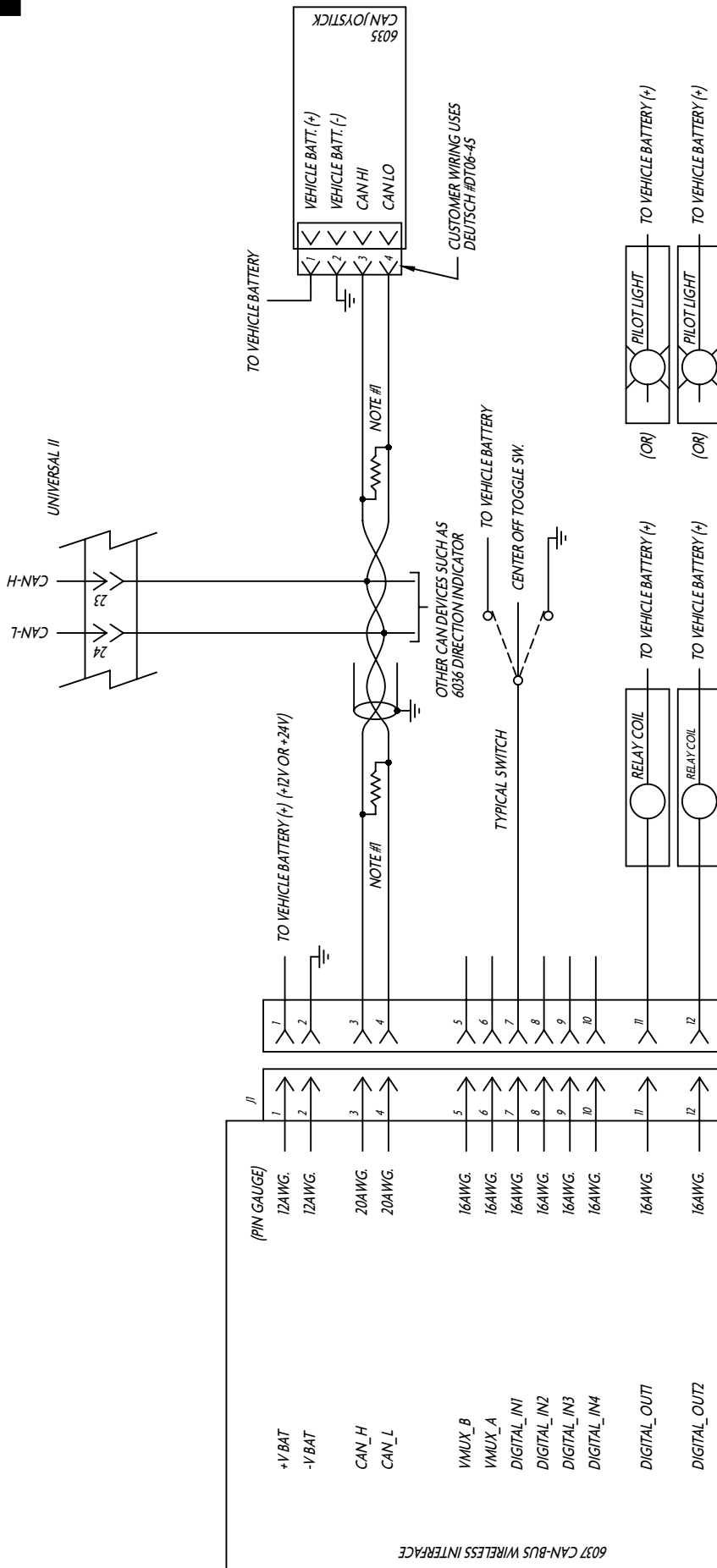

NOTES:

1) J1939 CAN REQUIRES 120 OHM TERMINATING RESISTORS AT EACH END OF NETWORK.

2) SEE DRAWING D-44723 FOR ADDITIONAL INFORMATION ON "CAN" WIRING.

OPERATING INSTRUCTIONS

NORMAL OPERATION

The 6035 CAN Pulse-Stream Joystick is Plug and Play, and comes ready to use. Once installed, the CAN Joystick can be used in conjunction with a Universal II control box to operate the monitor/turret.

NOTE: The 6035 CAN Pulse-Stream Joystick is designed to be as benign as possible on a typical J1939 network. It performs standard address claiming. It issues standard J1939 Joystick messages. The CAN Joystick's default mode is Joystick 3. It is possible to change this in the field by using the setup mode. It is possible to have multiple Universal II's and CAN Joysticks on the same network. Contact Akron Brass customer support for custom software if this is a requirement.

 **WARNING** For fire fighting use only by trained fire fighters.

 **WARNING** Do not use the Joystick when the override cranks are being used or are in position for use.

The joystick is proportional in the X and Y axis. Pushing the joystick forward will lower the monitor/turret nozzle. The farther forward the joystick is pushed, the faster will be the motion. Pulling the joystick back will raise the monitor/turret nozzle. Moving the joystick to the right will rotate the monitor/turret to the right. Moving the joystick to the left will rotate the monitor/turret to the left.

The “trigger” switch is used to open and close the water/foam discharge valve. (This assumes the discharge valve has been wired to the appropriate output on the Universal II) Squeezing the trigger switch will open the valve, and releasing the trigger switch will close the valve. The valve may be placed in a continuously open condition by “double-clicking” the trigger switch. The next activation of the trigger switch will return it to normal momentary operation.

On top of the joystick is a thumb switch used to control the pattern sleeve of the nozzle. Moving the thumb switch to the right will move the pattern sleeve towards the straight stream position. Moving the thumb switch to the left will move the pattern sleeve towards the fog position. In both cases, the pattern sleeve will stop when the thumb switch returns to center position, or the pattern sleeve reaches the full extent of its travel. This permits a continuously adjustable discharge pattern.

On the left side of the joystick is the “PULSE” mode button. This button selects the pulse mode of the associated 86203XXX electric valve. Press this button momentarily to place the system into pulse mode with the minimum pulse time (approximately 1.5 seconds). To lengthen the pulse time, press the valve trigger to open the valve and press and hold the pulse button to hold the valve open for the desired pulse length then release the pulse button. The valve will now open and remain open for that time interval. If the trigger is “double clicked” while in pulse mode, the valve will repeat the programmed pulse time until the trigger is clicked again to close the valve. On the right side of the joystick is the “STREAM” mode button. This button selects the stream (normal) mode. Upon power up, the joystick is automatically placed in the stream mode. In stream mode, the joystick trigger opens the valve, and when released, closes the valve. If the trigger is “double clicked,” the valve will open and remain open until the trigger is clicked once more which will close the valve.

SETUP AND CALIBRATION

Changes to the behavior of the joystick can be achieved by entering the setup mode. This can be done in the field with a small magnet. Three small dots located on the connector label (see Figure 4) identify the location of Hall Effect switches inside the joystick.

Zeroing and Spanning the Joystick

Place a magnet over the Switch 1 dot for approximately one second (see Figure 4). All three LEDs will begin flashing the priority level (the default will be three flashes). Momentarily place the magnet over Switch 3. The Green LED will begin flashing by itself signaling the joystick has entered calibration mode. Allow the joystick to return to the centered position (at rest). Momentarily place the magnet over Switch 3. The Yellow LED will begin flashing by itself signaling the joystick has been zeroed. Move the joystick to any one of its four corners (maximum X and Y deflection). While holding the joystick at its maximum, momentarily place a magnet over Switch 3. At this point, all three LEDs will begin flashing the priority level signaling the joystick has been spanned.

Either cycling power or momentarily placing a magnet over Switch 2 will reset the joystick and return it to normal operation.

Changing the Priority Level

The SAE J1939/71 specification has made provisions for up to six joysticks residing on the same CAN bus (Joystick1 through Joystick6). Akron Brass has chosen to interpret this assignment as the priority level. Joystick1 has the highest priority, and Joystick6 has the lowest priority. A device at Joystick3 issuing “go right” messages would override a device at Joystick5 issuing “go left” messages. Akron Brass has set the default for the 6041 CAN Switch Box at Joystick1, the 6035 CAN Joystick at Joystick3, and the 6037 CAN Wireless Interface at Joystick5. Customers may require a different priority scheme. The following steps allow field changing of priority level.

Place a magnet over the Switch 1 dot for approximately one second (see Figure 4). All three LEDs will begin flashing the current priority level (the default will be three flashes). Momentarily placing a magnet over Switch 1 again will increase the Joystick number (decrease the priority) by one. Continue with momentarily placing a magnet over Switch 1 until the desired priority level has been reached. When Joystick6 has been reached, another Switch 1 activation will wrap around to Joystick1. When the desired priority level has been reached, momentarily place a magnet over Switch 2 to save the setting and the Joystick will reset and return to normal operation.

NOTE: There cannot be two devices with the same priority level. If two devices are assigned the same priority level, only one will remain active on the network. The remaining device will become inactive and claim CAN node address 254 as defined and specified by SAE J1939.

MAINTENANCE INSTRUCTIONS

The 6035 CAN Joystick has no user serviceable parts. If the device fails to operate properly, please contact an Akron Brass customer service representative.

TROUBLESHOOTING

DIAGNOSTIC LEDs

The CAN Joystick has three LEDs located near the connector labeled Ready, Receive, and Transmit. Their colors are Green, Yellow, and Red respectively. Under normal operation, the Green Ready LED indicates the unit is powered and that the unit's microprocessor is running. The Yellow LED will blink on and off when there are CAN messages sent by other devices on the network that pertain to the Joystick. The Red LED will light when the joystick is sending CAN messages that contain non-centered joystick positions or other switch operations. When the joystick returns to a quiescent state, the Red LED will turn off.

Make sure that no two CAN operator devices (Joystick, Wireless, or Switch Box) have identical priority settings, otherwise one of them will become inactive.

AKROVIEW SOFTWARE

As with all of the Akron Brass CAN product family, the 6035 CAN Joystick supports the Akroview Software. The software provides additional diagnostics as well as software updating and other capabilities. Contact Akron Brass for additional information on how you can obtain a copy of Akroview software.



PHONE: 330.264.5678 or 800.228.1161 | FAX: 330.264.2944 or 800.531.7335 | akronbrass.com

REVISED: 9/16

WARRANTY AND DISCLAIMER: We warrant Akron Brass products for a period of five (5) years after purchase against defects in materials or workmanship. Akron Brass will repair or replace product which fails to satisfy this warranty. Repair or replacement shall be at the discretion of Akron Brass. Products must be promptly returned to Akron Brass for warranty service.

We will not be responsible for: wear and tear; any improper installation, use, maintenance or storage; negligence of the owner or user; repair or modification after delivery; damage; failure to follow our instructions or recommendations; or anything else beyond our control. WE MAKE NO WARRANTIES, EXPRESS OR IMPLIED, OTHER THAN THOSE INCLUDED IN THIS WARRANTY STATEMENT, AND WE DISCLAIM ANY IMPLIED WARRANTY OF MERCHANTABILITY OR FITNESS FOR ANY PARTICULAR PURPOSE. Further, we will not be responsible for any consequential, incidental or indirect damages (including, but not limited to, any loss of profits) from any cause whatsoever. No person has authority to change this warranty.

© Akron Brass Company. 2015 All rights reserved. No portion of this can be reproduced without the express written consent of Akron Brass Company.