

OPTIONAL 3.5 NH SWIVEL

"IMPORTANT" INSTALLATION INSTRUCTIONS STYLE 5075

THE STYLE 5075, WITH OPTIONAL 3.5" SWIVEL HAS A FULL TIME SWIVEL AND MUST BE LOCKED IN PLACE AS FOLLOWS:

1. THREAD THE NOZZLE ONTO THE MONITOR OUTLET.
2. ROTATE THE MOTOR INTO REQUIRED LOCATION.
3. TIGHTEN THE SOCKET HEAD SET SCREW IN THE SIDE OF THE SWIVEL USING A 3/16" HEX WRENCH.
4. PLUG IN MOTOR CONNECTOR.

MAXIMUM OPERATING PRESSURE: 200 PSI.

FLOW RATING: 250 - 1250 GPM AT 80 PSI.

WARNING: THE ELECTRICAL CONTROL SYSTEM MUST INCORPORATE A CURRENT LIMITING CIRCUITRY SET FOR A MAXIMUM OF 3 AMPS FOR 12 VOLTS (1.5 AMPS FOR 24 VOLTS). WITHOUT CIRCUITRY SET MOTOR MAY BECOME INOPERABLE IF STALLED DURING OPERATION.

NOTES:

USE PARKER O-RING ON ALL O-RINGS AND MATING SURFACES UNLESS OTHERWISE NOTED.

USE PERMABOND LM113 OR LOCTITE 222

TIGHTEN CONE POINT SET SCREW BETWEEN TWO BALL BEARINGS UNTIL IT BOTTOMS OUT IN SWIVEL PLUG HOLE (SWIVEL SHOULD BE FIXED). THEN BACK OUT APPROX. ONE TURN UNTIL SWIVEL TURNS SMOOTHLY. THEN STAKE THE FIRST THREAD TO PREVENT SCREW FROM BACKING OUT.

ITEM NO.	DESCRIPTION	PART NO.	QUANTITY
1	590 GPM BAFFLE SUB-ASSEMBLY	50751017	1
	660 GPM BAFFLE SUB-ASSEMBLY	50571018	
	750 GPM BAFFLE SUB-ASSEMBLY	50751019	
	800 GPM BAFFLE SUB-ASSEMBLY	50571020	
	1000 GPM BAFFLE SUB-ASSEMBLY	50751021	
	1250 GPM BAFFLE SUB-ASSEMBLY	50751022	
12	THROAT	108380	1
16	SWIVEL (2-1/2" NH) **	101420	1
16	SWIVEL (3-1/2" NH) **	118779	1
17	BALL BRASS	703017	***
18	SWIVEL PLUG	742023	1
19	SWIVEL GASKET (2-1/2")	717043	1
19	SWIVEL GASKET (3-1/2")	714023	1
20	PATTERN SLEEVE	108378	1
21	O-RING 2-149	757087	1
22	O-RING 2-343	757319	1
28	FLAT PATTERN RING	119613	1
29	10-24 X 1/4 SET SCREW	767103	3
40	3/8-24 X 1/2 SET SCREW	765186	1
57	ID BAND 750 GPM	704691	1
57	ID BAND 1250 GPM	704692	1
102	ACTUATOR ASSEMBLY	50751016	1
103	12V MOTOR ASSEMBLY WITH SPEED CLIP	50770028	1
	24V MOTOR ASSEMBLY WITH SPEED CLIP	50770029	
	12V MOTOR ASSEMBLY WITH DEUTSCH CONNECTOR	33560006	
	24V MOTOR ASSEMBLY WITH DEUTSCH CONNECTOR	33560008	
104 +	O-RING 2-015	757112	1
109 +	O-RING 2-029	757056	1
111 +	SCREW 6-32 X 1/2	765150	4
121	SCREW 5/16-18 X 1-3/4	766052	1
123	PATTERN STOP	769509	1
124	SCREW 10-24 X 1/2	763038	2
135	SPACER	768257	1
146	O-RING 2-156	757080	1

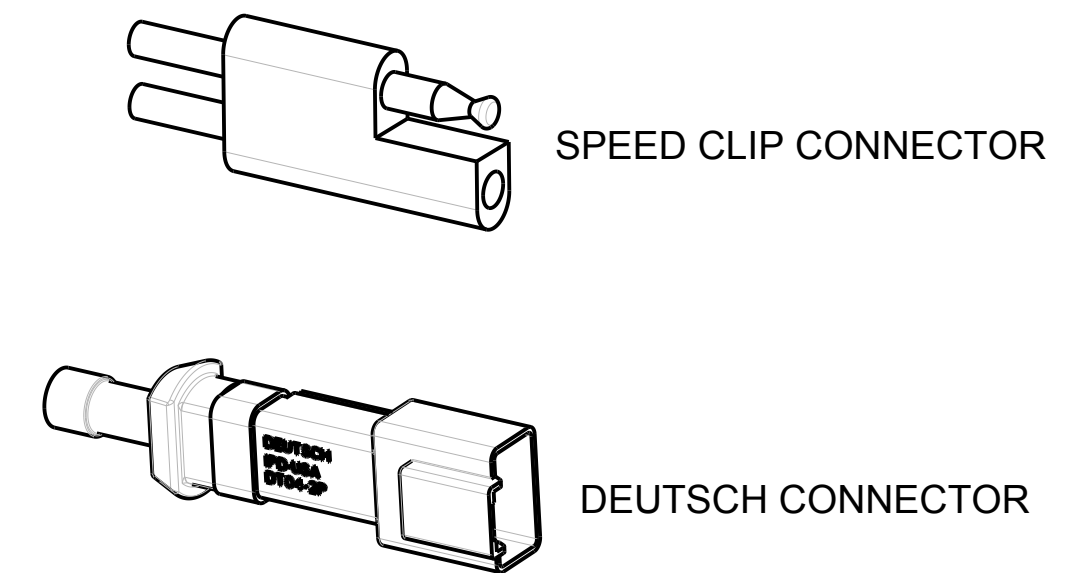

\*\* FOR OTHER THREADS ORDER BY DESCRIPTION AND THREAD SIZE (ODM AND TPI) OR BY AKRON THREAD CODE.

\*\*\* PACKET OF 50 BALL BEARINGS - P/N 109041

+ MOTOR ASSEMBLY INCLUDES MARKED ITEMS