

Chg.	Date
00	04-13
01	10-19

ASSEMBLY NOTES:

USE PARKER O-LUBE ON ALL O-RINGS AND MATING SURFACES UNLESS OTHERWISE NOTED.

- ① USE PLIOBOND INDUSTRIAL ADHESIVE.
- ② USE PVC CEMENT.
- ③ USE PERMABOND LH050 OR LOCTITE 592 PIPE SEALANT.
- ④ DO NOT CONNECT ITEM 33 TO ITEM 27 FOR SHIPPING.
- ⑤ USE PERMABOND LM113 OR LOCTITE 222.

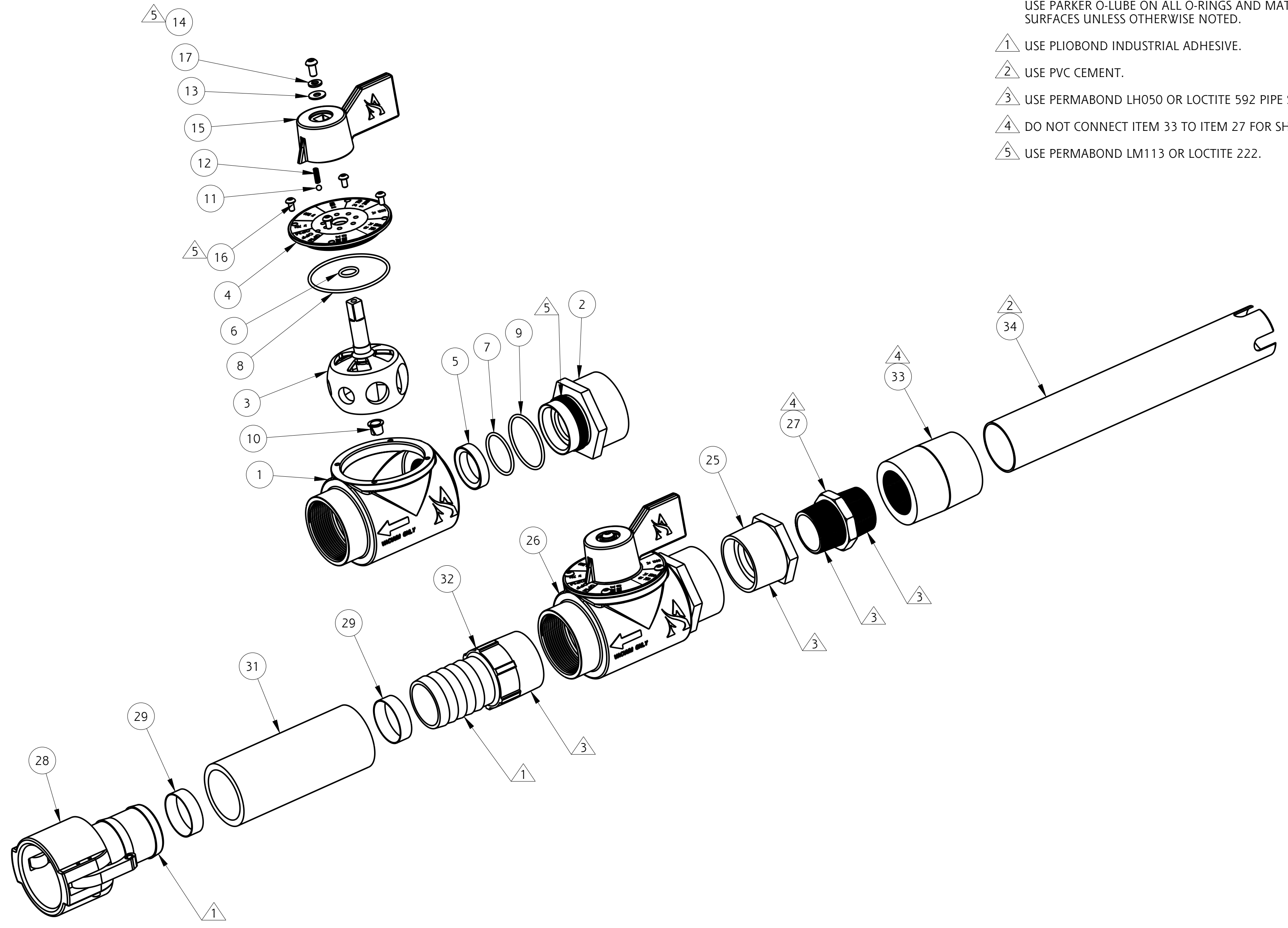

PHONE: 330.264.5678 or 800.228.1161 | FAX: 330.264.2944 or 800.531.7335 | www.akronbrass.com

WARRANTY AND DISCLAIMER*: We warrant Akron Brass products for a period of five (5) years* after purchase against defects in materials or workmanship. Akron Brass will repair or replace product which fails to satisfy this warranty. Repair or replacement shall be at the discretion of Akron Brass. Products must be promptly returned to Akron Brass for warranty service. We will not be responsible for: wear and tear; any improper installation, use, maintenance or storage; negligence of the owner or user; repair or modification after delivery; failure to follow our instructions or recommendations; or anything else beyond our control. WE MAKE NO WARRANTIES, EXPRESS OR IMPLIED, OTHER THAN THOSE INCLUDED IN THIS WARRANTY STATEMENT, AND WE DISCLAIM ANY IMPLIED WARRANTY OF MERCHANTABILITY OR FITNESS FOR ANY PARTICULAR PURPOSE. Further, we will not be responsible for any consequential, incidental or indirect damages (including, but not limited to, any loss of profits) from any cause whatsoever. No person has authority to change this warranty. *Unless otherwise provided herein. Akron Brass industrial electronic components & the Severe-Duty Monitor have a one (1) year warranty. Select Akron Brass handline nozzles and valves carry a ten (10) year warranty. Scene Star Lights carry a (6) year warranty. Weldon products have a two (2) year warranty from date of manufacture (excluding consumable components). Select Weldon LED products carry a five (5) year warranty. Honda products have the manufacturers' warranty and Akron Brass disclaims any warranty in respect of those products.

Parts List Sheet:

123894



TECHNICAL SERVICE PARTS

STYLE 4478

PRODUCT AKROFOAM PICKUP ASSEMBLY

IF AN ITEM IS NOTED AS "NOT FIELD REPAIRABLE", OR YOU WISH TO RETURN AN ITEM TO AKRON BRASS FOR SERVICE PLEASE GO ONLINE TO, **ONLINEREPAIR.AKRONBRASS.COM**

Chg.	Date
00	04-13
01	10-19

Find	Description	Item	Qty
1	BODY VALVE	123896	1
2	ADAPTER OUTLET	123893	1
3	BALL METERING	123895	1
4	CAP METERING VALVE - GPM	123891	1
4	CAP METERING VALVE - LPM	123892	1
5	SEAT METERING BALL	769945	1
6	O-RING 2-113	757008	1
7	O-RING 2-128	757283	1
8	O-RING 2-150	757522	1
9	O-RING 2-136	757083	1
10	BEARING NYLINER	704235	1
11	BALL 3/16"	704018	1
12	SPRING DETENT	769111	1
13	WASHER FLAT 1/4"	784075	1
14	SCREW SOCKET HEAD BUTTON 1/4-20 x 1/2"	765153	1
15	HANDLE	123897	1
16	SCREW BUTTON HEAD #10-24 x 3/8"	765143	4
17	WASHER SPLIT LOCK 1/4"	784106	1
25	BUSHING 2"NPT x 1-1/2" NPT	803024	1
26	VALVE 2" NPT	44780006*	1
27	NIPPLE 1-1/2" NPT	736053	1
28	CONNECTOR CAM AND GROOVE	707985	1
29	CLAMP DIXON	707166	2
31	HOSE 2" ID x 120" LG	721642	1
32	NIPPLE 2" NPT	736062	1
33	CONNECTOR STRAIGHT	707268	1
34	TUBE PICK UP	772118	1

* ASSEMBLY FOR ITEMS 1 THROUGH 17

PHONE: 330.264.5678 or 800.228.1161 | FAX: 330.264.2944 or 800.531.7335 | www.akronbrass.com

WARRANTY AND DISCLAIMER*: We warrant Akron Brass products for a period of five (5) years* after purchase against defects in materials or workmanship. Akron Brass will repair or replace product which fails to satisfy this warranty. Repair or replacement shall be at the discretion of Akron Brass. Products must be promptly returned to Akron Brass for warranty service. We will not be responsible for: wear and tear; any improper installation, use, maintenance or storage; negligence of the owner or user; repair or modification after delivery; failure to follow our instructions or recommendations; or anything else beyond our control. WE MAKE NO WARRANTIES, EXPRESS OR IMPLIED, OTHER THAN THOSE INCLUDED IN THIS WARRANTY STATEMENT, AND WE DISCLAIM ANY IMPLIED WARRANTY OF MERCHANTABILITY OR FITNESS FOR ANY PARTICULAR PURPOSE. Further, we will not be responsible for any consequential, incidental or indirect damages (including, but not limited to, any loss of profits) from any cause whatsoever. No person has authority to change this warranty. *Unless otherwise provided herein. Akron Brass industrial electronic components & the Severe-Duty Monitor have a one (1) year warranty. Select Akron Brass handline nozzles and valves carry a ten (10) year warranty. Scene Star Lights carry a (6) year warranty. Weldon products have a two (2) year warranty from date of manufacture (excluding consumable components). Select Weldon LED products carry a five (5) year warranty. Honda products have the manufacturers' warranty and Akron Brass disclaims any warranty in respect of those products.

Parts List Sheet:

123894