

THIS DRAWING AND ALL INFORMATION CONTAINED HEREIN IS THE PROPERTY OF WELDON TECHNOLOGIES, INC. AND MAY NOT BE COPIED, REPRODUCED, OR DEVIOLGED TO UNAUTHORIZED PERSONS WITHOUT THE EXPRESS WRITTEN CONSENT OF WELDON TECHNOLOGIES, INC. AS IT IS BEING PROVIDED SOLELY FOR THE CONVENIENCE OF THE USER AND SHALL BE RETURNED TO WELDON TECHNOLOGIES, INC. UPON REQUEST.

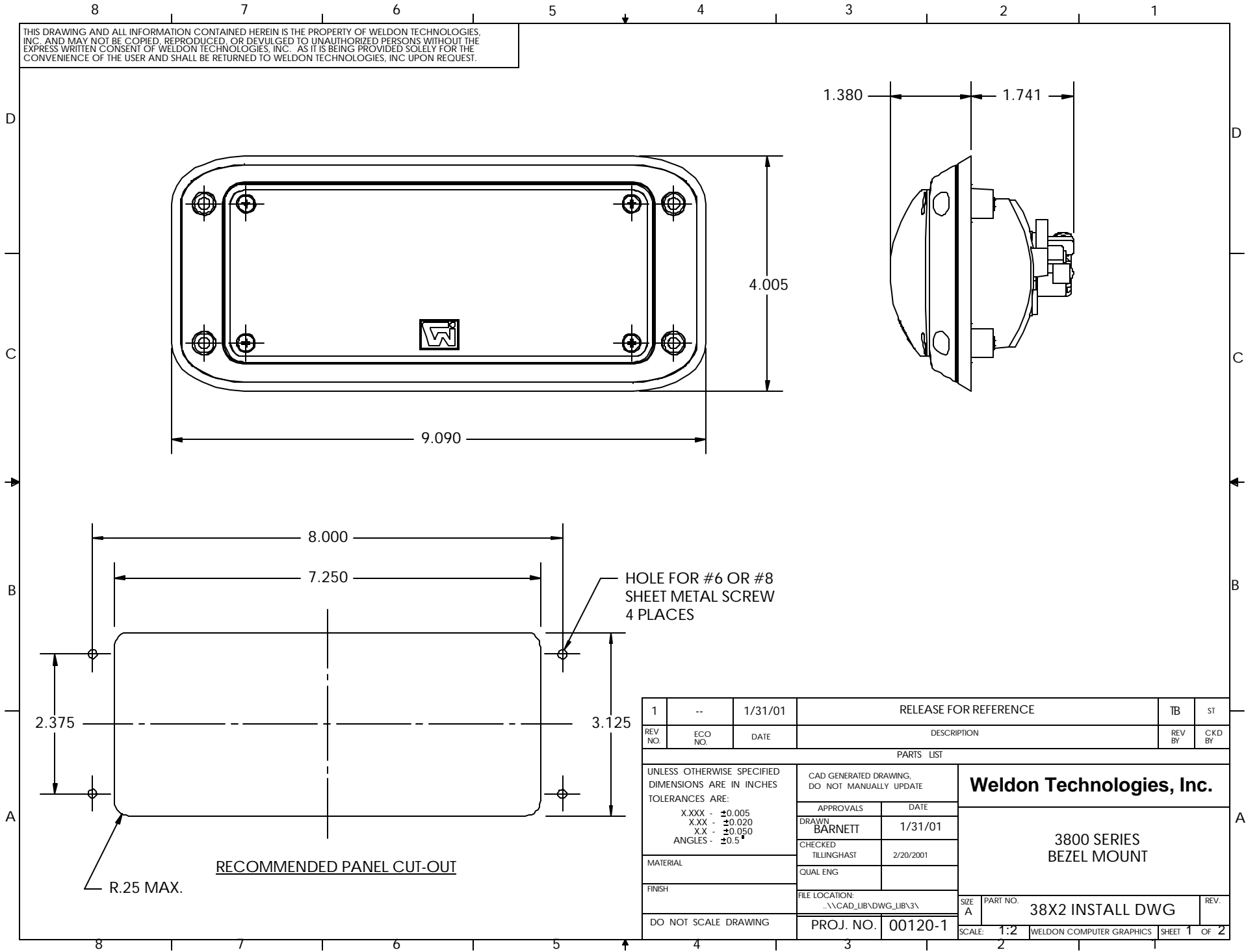

1	--	1/31/01	RELEASE FOR REFERENCE	TB	ST
REV NO.	ECO NO.	DATE	DESCRIPTION	REV BY	CKD BY
PARTS LIST					
UNLESS OTHERWISE SPECIFIED DIMENSIONS ARE IN INCHES TOLERANCES ARE: X.XXX - ±0.005 X.XX - ±0.020 X.X - ±0.050 ANGLES - ±0.5°		CAD GENERATED DRAWING. DO NOT MANUALLY UPDATE		Weldon Technologies, Inc. 3800 SERIES BEZEL MOUNT	
MATERIAL		APPROVALS	DATE		
FINISH		DRAWN BARNETT	1/31/01		
DO NOT SCALE DRAWING		CHECKED TILLINGHAST	2/20/2001		
		QUAL ENG		SIZE A	PART NO. 38X2 INSTALL DWG
		FILE LOCATION: ...\\CAD_LIB\DWG_LIB\3\		SCALE: 1:2	WELDON COMPUTER GRAPHICS SHEET 1 OF 2
		PROJ. NO. 00120-1			REV.