

ASSEMBLY NOTES:

- USE MOBILITH SHC 460 ON ALL O-RINGS AND MATING SURFACES UNLESS OTHERWISE NOTED.
- 1 USE PERMABOND LM113 OR LOCTITE 222.
- 2 USE PRIMER T AND PERMABOND HH120 OR LOCTITE 277.
- 3 USE LOW-TEMP LUBRIPLATE.
- 4 DIMPLE AT ASSEMBLY.
- 5 THOROUGHLY COAT WITH NEVER SEEZ MARINERS CHOICE.
- 6 FOR THREADS UP TO \varnothing 2": USE PERMABOND LH050 OR LOCTITE 592. FOR THREADS BIGGER THAN \varnothing 2": USE AGRO "TUF-GLIDE THREAD SEALANT WITH PTFE".
- 7 USE LOCTITE 290.
- 8 GENERAL DEPICTION SEE BILL OF MATERIAL.
- 9 ALIGN BALL IN HOLE. TIGHTEN PLUG UNTIL TOUCHES BALL. THEN BACK OUT PLUG 1/4-1/2 TURN.

- 10 USE MOBILITH SHC 460 GREASE.
- 11 USE SIKAFLEX-IA SEALANT.
- 12 ASSEMBLE RETAINING RING (ITEM 62) WITH SHARP CORNERS AWAY FROM MOTOR ADAPTER (ITEM 40).
- 13 STAMP SERIAL NUMBER, VOLTAGE, AND 4 DIGIT STYLE NUMBER IN THE "STYLE" BOX.
- 14 CUT WIRES AND SEAL WITH SIKAFLEX-1A SEALANT. DRILL 3/16" HOLE THRU CENTER OF PLUG AND ATTACH. CONNECT NOZZLE HARNESS FOR SHIPMENT.
- 15 EXCEPT FOR WATERWAY PARTS AND STOP LOCATIONS, BOTH JOINTS ARE IDENTICAL.
- 16 STUDS ARE NOT EQUALLY SPACED.
- 17 CLEAN AND PRIMER BEFORE USING LOCTITE OR PERMABOND.
- 18 ALLOW TO CURE FULLY PRIOR TO CONTINUING ASSEMBLY PROCESS.

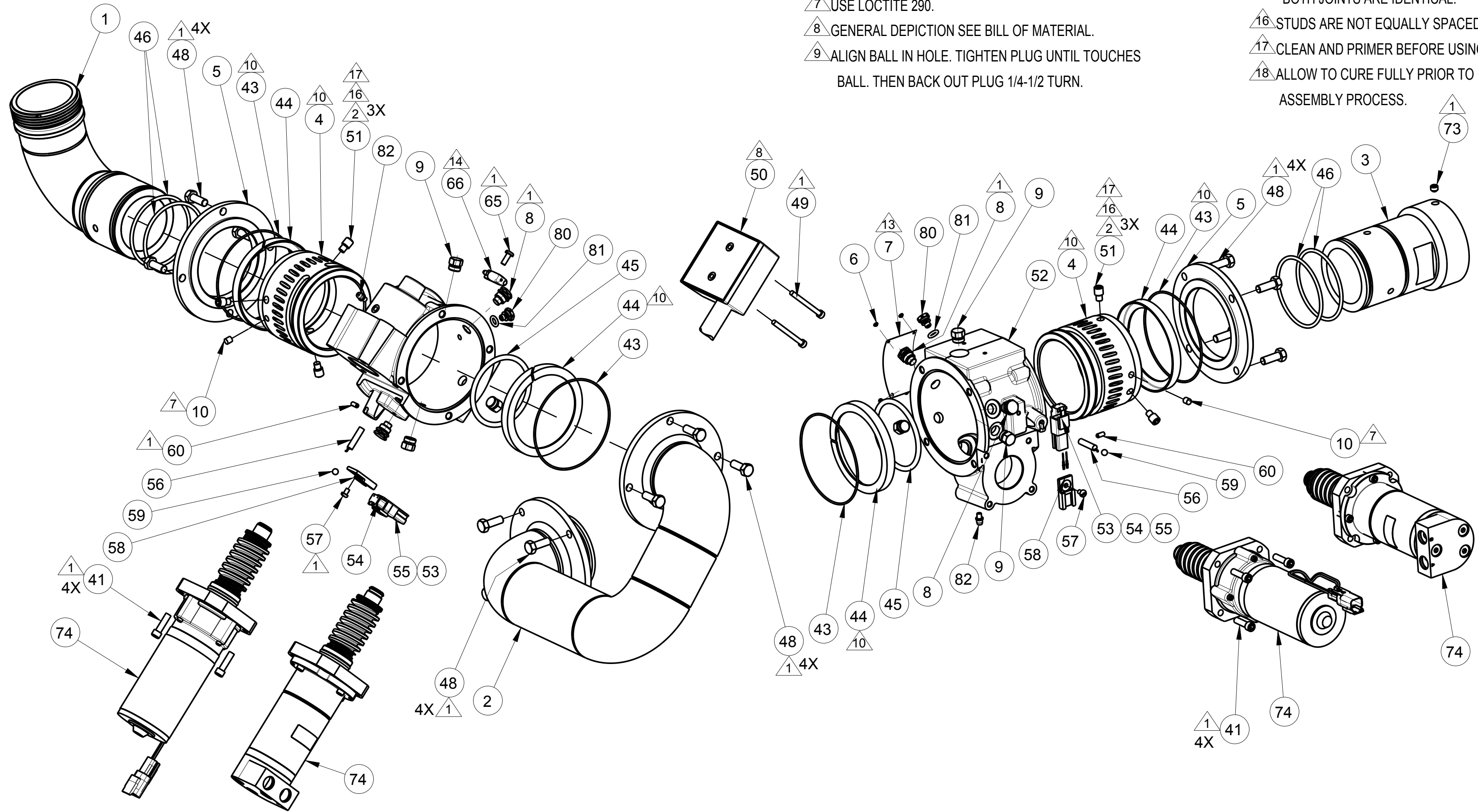

PHONE: 330.264.5678 or 800.228.1161 | FAX: 330.264.2944 or 800.531.7335 | www.akronbrass.com

Parts List Sheet:

124566

WARRANTY AND DISCLAIMER*: We warrant Akron Brass products for a period of five (5) years* after purchase against defects in materials or workmanship. Akron Brass will repair or replace product which fails to satisfy this warranty. Repair or replacement shall be at the discretion of Akron Brass. Products must be promptly returned to Akron Brass for warranty service. We will not be responsible for: wear and tear; any improper installation, use, maintenance or storage; negligence of the owner or user; repair or modification after delivery; failure to follow our instructions or recommendations; or anything else beyond our control. WE MAKE NO WARRANTIES, EXPRESS OR IMPLIED, OTHER THAN THOSE INCLUDED IN THIS WARRANTY STATEMENT, AND WE DISCLAIM ANY IMPLIED WARRANTY OF MERCHANTABILITY OR FITNESS FOR ANY PARTICULAR PURPOSE. Further, we will not be responsible for any consequential, incidental or indirect damages (including, but not limited to, any loss of profits) from any cause whatsoever. No person has authority to change this warranty. *Unless otherwise provided herein. Akron Brass industrial electronic components & the Severe-Duty Monitor have a one (1) year warranty. Select Akron Brass handline nozzles and valves carry a ten (10) year warranty. Scene Star Lights carry a (6) year warranty. Weldon products have a two (2) year warranty from date of manufacture (excluding consumable components). Select Weldon LED products carry a five (5) year warranty. Honda products have the manufacturers' warranty and Akron Brass disclaims any warranty in respect of those products.



TECHNICAL SERVICE PARTS

STYLE 3490, 3491

PRODUCT MINING MONITOR

IF AN ITEM IS NOTED AS "NOT FIELD REPAIRABLE", OR YOU WISH TO RETURN AN ITEM TO AKRON BRASS FOR SERVICE PLEASE GO ONLINE TO, **ONLINEREPAIR.AKRONBRASS.COM**

Chg.	Date
02	02-17
03	01-18

Find	Description	Item	Qty
1	ELBOW OUTLET	710132	1
2	GOOSENECK	718254	1
3	INLET 2.5" NPT	723040	1
4	GEAR WORM	718229	2
5	CAP JOINT	119719	2
6	NAIL GRIP 3/16 DIA	736052	4
7	PLATE ID (ELECTRIC)	745267	1
7	PLATE ID (HYDRAULIC)	745290	1
8	STOP	769498	4
9	PLUG 1/2-20 X 1/2	744337	6
10	MAGNET NICKEL RARE EARTH	731081	2
42	O-RING 2-142	757043	2
43	O-RING 2-045	757427	4
44	BEARING POLYETHYLENE	704781	4
45	O-RING 2-336	757074	2
46	O-RING 2-234	757029	4
48	SCREW HEX HD CAP 5/16-18 X 7/8"	763028	16
49	SCREW SOC HD CAP 10-24 X 2	763077	2
50	HARNESS WIRING	721479	1
51	STUD	769727	6
52	JOINT	124532	2
53	RECEPTACLE DEUTSCH DTM04-2P	758231	2
54	CONTACT PIN DEUTSCH 0460-202-20141	744379	4
55	WEDGE LOCK DEUTSCH WM-2P	784131	2
56	SWITCH HAMLIN ROUND	769599	2
57	SCREW #8-32X1/4"PHILLIPS PAN HD	765208	2
58	CLIP MOUNTING DEUTSCH 1011-026-0205	704589	2
59	BALL RUBBER 1/4"OD	703544	2
60	SCREW HEX SOC SET 8-32 X 3/8"CUP	765074	2
65	SCREW PAN HD 10-24 X 1/2"	767147	1
66	CLIP SPEED	707219	1
71	NIPPLE 2.5" NPT x 6"	735076	1
72	FLANGE 3" 150# W/ 2.5" NPT	712285	1
73	SCREW SOC HD SET CUP PT 5/16-18 X 1/4	765071	1
74	MOTOR GEARBOX S/A 12V	34912002	2
74	MOTOR GEARBOX S/A 24V	34912003	2
74	MOTOR S/A HYDRAULIC	34922002	2
80	VENT BREATHER	779089	2
81	O-RING 2-109	757349	2
82	FITTING GREASE	713191	2

SUB ASSEMBLY & ACCESSORIES PARTS LIST	
BOX LOGIC W/CONNECTORS,12/24V FF, MINING MON	34911000
BOARD PC 12/24V W/CLMT TRAVEL EA REPAIR	34630034
20'/6 METRE WIRING HARNESS WITH IP67 DEUTSCH PLUGS	707526
33'/10 METRE WIRING HARNESS WITH IP67 DEUTSCH PLUGS	707527
40'/12METRE WIRING HARNESS WITH IP67 DEUTSCH PLUGS	707528
RAMPAGE ELECT NZ,SD,2.5NH,12V, 500-1000 GPM	44620004
RAMPAGE ELECT NZ,SD,2.5NH,24V, 500-1000 GPM	44620003
AKROFOAM NZ 24V,2.5NH,NZ BOOT,350-1000 GPM	44710006
JOYSTICK FOR MINING MONITOR	34911001
MOTOR GEARBOX S/A W/JOINT 12V	34912005
MOTOR GEARBOX S/A W/JOINT 24V	34912006
MOTOR S/A W/JOINT HYDRAULIC	34922001
GEAR RING REPLACEMENT KIT	* 34912009
3" FLANGE/2.50"NPT NIPPLE ASSEMBLY	34910003

COMPLETE ASSEMBLY	
MON SD S/A 3FLG X 2.5 NH,24V SS, BLK,SPC	34912008
MON SD S/A 3FLG X 2.5 NH,12V SS, BLK,SPC	34912004
MON SD HYD 3FLGX2.5NPTX2.5NH,SS,BLK	34922000

NOTES:
 MOBILITH SHC 460 GREASE: 92100001
 * KIT INCLUDES FINDS 4, 43, 44, 45, 46, 51, ITEM 92100001

PHONE: 330.264.5678 or 800.228.1161 | FAX: 330.264.2944 or 800.531.7335 | www.akronbrass.com

Parts List Sheet:

124566

WARRANTY AND DISCLAIMER*: We warrant Akron Brass products for a period of five (5) years* after purchase against defects in materials or workmanship. Akron Brass will repair or replace product which fails to satisfy this warranty. Repair or replacement shall be at the discretion of Akron Brass. Products must be promptly returned to Akron Brass for warranty service. We will not be responsible for: wear and tear; any improper installation, use, maintenance or storage; negligence of the owner or user; repair or modification after delivery; failure to follow our instructions or recommendations; or anything else beyond our control. WE MAKE NO WARRANTIES, EXPRESS OR IMPLIED, OTHER THAN THOSE INCLUDED IN THIS WARRANTY STATEMENT, AND WE DISCLAIM ANY IMPLIED WARRANTY OF MERCHANTABILITY OR FITNESS FOR ANY PARTICULAR PURPOSE. Further, we will not be responsible for any consequential, incidental or indirect damages (including, but not limited to, any loss of profits) from any cause whatsoever. No person has authority to change this warranty. *Unless otherwise provided herein. Akron Brass industrial electronic components & the Severe-Duty Monitor have a one (1) year warranty. Select Akron Brass handline nozzles and valves carry a ten (10) year warranty. Scene Star Lights carry a (6) year warranty. Weldon products have a two (2) year warranty from date of manufacture (excluding consumable components). Select Weldon LED products carry a five (5) year warranty. Honda products have the manufacturers' warranty and Akron Brass disclaims any warranty in respect of those products.

© 2016 Akron Brass Company. All rights reserved. No portion of this can be reproduced without the express written consent of the Akron Brass Company.