

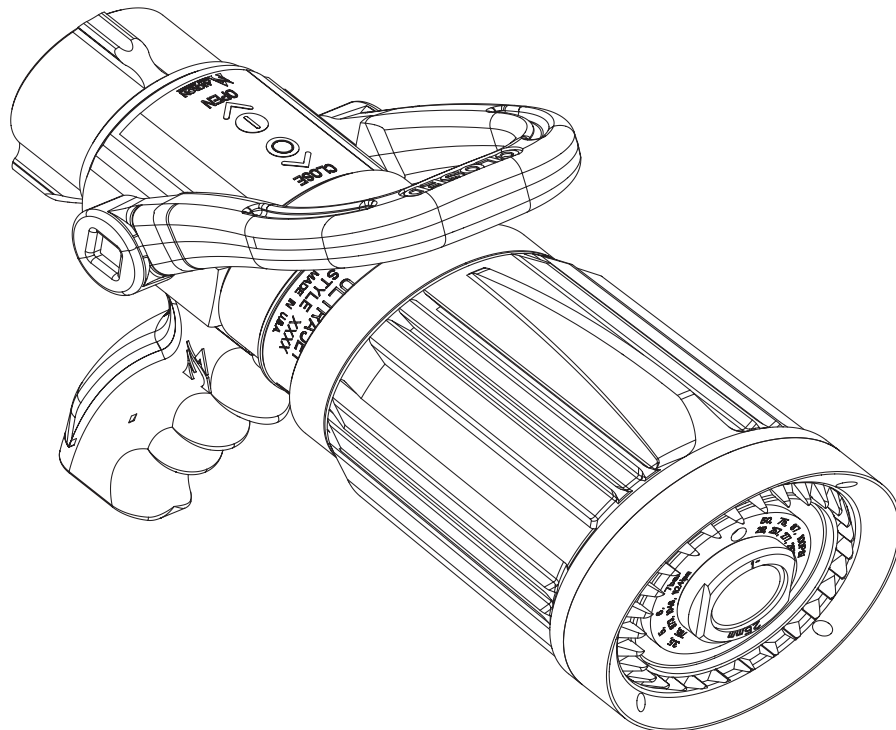

STYLE 1820 Ultrajet™ Nozzle OPERATING AND MAINTENANCE INSTRUCTIONS

The following is intended to provide the basic instructions for operation, and maintenance. Read and understand these operating instructions before use.



⚠ WARNING Read and follow the operating instructions before use.

⚠ WARNING For firefighting use only.

PRODUCT RATINGS

Maximum operating pressure: 230 psi/16 bar/1600 kpa

PRODUCT WARNINGS

- | | |
|------------------|--|
| ⚠ DANGER | • Indicates a hazardous situation which, if not avoided, WILL result in death or serious injury. |
| ⚠ WARNING | • Indicates a hazardous situation which, if not avoided, COULD result in death or serious injury. |
| ⚠ CAUTION | • Indicates a potentially hazardous situation which, if not avoided, may result in minor or moderate injury. |
| NOTICE | • Addresses practices not related to personal injury. |

- ⚠ DANGER**
- ⚠ WARNING**
 - Not for use on electrical fires.
- ⚠ WARNING**
 - Charge all lines slowly to facilitate a controlled water pressure build-up during start-up. Open and close slowly. Rapid opening will produce a sudden thrust. Rapid opening and closing can cause water hammer. Have enough firefighters on the line to safely control the reaction force created by the stream.
- ⚠ WARNING**
 - At pressures below that indicated on the label, the nozzle will have reduced flow and reach. Be sure you have enough flow and pressure for the situation (See IFSTA and NFPA manuals for guidelines).
- ⚠ WARNING**
 - The amount of flow to a nozzle is controlled at the pump, not at the nozzle. Therefore, unanticipated increases and decreases in flow can occur without the knowledge of the nozzle operator. This can cause serious consequences (i.e. too little flow to extinguish the fire, or increased reaction force which the nozzle operator may be unable to handle).
- ⚠ WARNING**
 - Do not use the nozzle in portable hose holders.
- ⚠ WARNING**
 - Ensure the nozzle is aimed in a direction that is safe, prior to opening the shutoff bale.
- ⚠ WARNING**
 - Ensure the thread on the nozzle swivel is matched to the thread on the hose connection.
- ⚠ WARNING**
 - Do not use the nozzle as a shut-off when testing hose.
- ⚠ WARNING**
 - When operating at lower pressures the hose can kink more easily. A kink in the hose chokes off the flow, which may result in inadequate flow for the situation.
- ⚠ WARNING**
 - Pulsing the shutoff can be accomplished with this nozzle. However, you must assure that all equipment used with the nozzles can withstand the resulting peak pressures and that the fire fighter is aware and can effectively support the sudden change in nozzle reaction when pulsing
- ⚠ WARNING**
 - When operating at lower pressures the hose can kink more easily. A kink in the hose chokes off the flow, which may result in inadequate flow for the situation.
- ⚠ CAUTION**
 - Your nozzle should be inspected prior to and after each use, to ensure it is in good operating condition. Periodically, an unanticipated incident may occur where the nozzle is used in a manner that is inconsistent with standard operating practices and those listed in IFSTA. A partial list of potential misuses follows:
 - Operating above maximum rated pressure and flow.
 - Not draining, and allowing water to freeze inside the nozzle.
 - Dropping the nozzle from a height where damage is incurred.
 - Prolonged exposure to temperatures above +130 degrees F, or below -25 degrees F.
 - Operating in a corrosive environment.
 - Other misuse that might be unique to your specific firefighting environment.
 - There are many “tell-tale” signs that indicate nozzle repair is in order, such as:
 - Controls that are inoperable or difficult to operate.
 - Excessive wear.
 - Poor discharge performance.
 - Water leaks.
 - If any of the above situations are encountered, the nozzle should be taken out of service and repaired, plus tested by qualified nozzle technicians, prior to placing it back in service.

CAUTION

- For firefighter use only.

CAUTION

- Do not over tighten the nozzle onto the hose connection.

NOTICE

- Do not use the nozzle as a forcible entry tool. Doing so may damage it or make it inoperable.

NOTICE

- If any tags or bands on the nozzle are worn or damaged and cannot be easily read, they should be replaced.

NOTICE

- For use with fresh water or standard firefighting foams only. Not recommended for use with salt water. After use with foam or salt water, flush with fresh water.

NOTICE

- When using with an eductor, make sure the nozzle is properly matched to the eductor. If they are not, the nozzle flow, pressure, and reach may be reduced or the eductor may shutdown. Do not throttle your nozzle with an eductor in the line. This can cause the eductor to shut down.

NOTICE

- The nozzle is configured for optimum performance. Do not alter in any manner.

NOTICE

- Do not expose the pistol grip or shutoff handle to Trichloroethylene or Trichlorethane. These chemicals can weaken the parts and make the nozzle inoperable over time.

NOTICE

- Drain the nozzle after use to prevent freeze damage.

OPERATING INSTRUCTIONS

BALL SHUTOFF

- Open and close slowly.
- To open: Pull the handle toward the inlet.
- To close: Push the handle towards the outlet.

NOZZLE

- The Ultrajet is designed to operate in a solid bore or fog pattern with a constant pressure and flow in either position. The straight stream is a solid bore tip. Typical operating pressures are 50psi (4bar), 75psi (5bar) and 87psi (6bar) when measured with a pitot gauge. The following solid bores are available and will flow the amount shown at the specified pitot pressure.

Tip Dia.	Flow @ 50psi (3.5bar)	Flow @ 75psi (5bar)	Flow @ 87psi (6bar)
3/4"	118gpm (450lpm)	145gpm (550lpm)	156gpm (590lpm)
7/8"	161gpm (610lpm)	197gpm (745lpm)	212gpm (805lpm)
15/16"	185gpm(700lpm)	226gpm (855lpm)	244gpm (925lpm)
1"	210gpm(795lpm)	257gpm (975lpm)	277gpm (1050lpm)

- To change the spray angle rotate the pattern sleeve/bumper. Rotate it clockwise for solid bore and counterclockwise for narrow fog and wide fog.
- To flush the nozzle, rotate the pattern sleeve/bumper counterclockwise to the FLUSH setting. Rotate slowly back to the required setting when obstruction is flushed.
- To remove the solid bore, place nozzle in wide fog and turn clockwise to loosen while looking at the discharge end of the nozzle. **NOTE: The solid bore has a left hand thread and therefore is tightened and loosened opposite of most threaded connections.**
- **IMPORTANT:** If a different diameter solid bore other than what is installed in the nozzle is replaced in the field then a preassembled baffle head must be purchased along with the new solid bore so the flow and pressure match in straight stream and fog pattern.
- To determine the required engine pressures to achieve the flow setting, use the following formula: Engine pressure (EP)= Friction Loss (FL) + Nozzle Pressure (NP) + pressure loss or gains due to elevation (1/2 psi per foot of height difference).

FOR USE WITH CAFS

- For optimal CAFS Bubble Structure place the nozzle pattern in solid stream and flow through the solid bore tip.

MAINTENANCE INSTRUCTIONS

- After use, flush the nozzle with clean water to clean grit and dirt from around exterior moving parts. Doing so will allow the nozzle to operate as designed.
- Over time the seals and turbine teeth may need replaced. This can be accomplished by purchasing the appropriate Akron repair kit. Use qualified maintenance mechanics or return the nozzle to Akron Brass for repair.
- Regularly check the solid bore tip to be sure it is tight
- Use low temp Lubriplate on metal parts and Parker™ O-Ring lubricant on O-Rings.

CARE, USE, INSPECTION, SERVICE TESTING, AND REPLACEMENT OF NOZZLES

- Reference the latest edition of NFPA 1962 Chapter 5 for the care, use, inspection, service testing, record keeping, and replacement of nozzles.



PHONE: 330.264.5678 or 800.228.1161 | FAX: 330.264.2944 or 800.531.7335 | akronbrass.com

REVISED: 06/17

WARRANTY AND DISCLAIMER: We warrant Akron Brass products for a period of five (5) years after purchase against defects in materials or workmanship. Akron Brass will repair or replace product which fails to satisfy this warranty. Repair or replacement shall be at the discretion of Akron Brass. Products must be promptly returned to Akron Brass for warranty service.

We will not be responsible for: wear and tear; any improper installation, use, maintenance or storage; negligence of the owner or user; repair or modification after delivery; damage; failure to follow our instructions or recommendations; or anything else beyond our control. WE MAKE NO WARRANTIES, EXPRESS OR IMPLIED, OTHER THAN THOSE INCLUDED IN THIS WARRANTY STATEMENT, AND WE DISCLAIM ANY IMPLIED WARRANTY OF MERCHANTABILITY OR FITNESS FOR ANY PARTICULAR PURPOSE. Further, we will not be responsible for any consequential, incidental or indirect damages (including, but not limited to, any loss of profits) from any cause whatsoever. No person has authority to change this warranty.

© Akron Brass Company, 2017 All rights reserved. No portion of this can be reproduced without the express written consent of Akron Brass Company.