

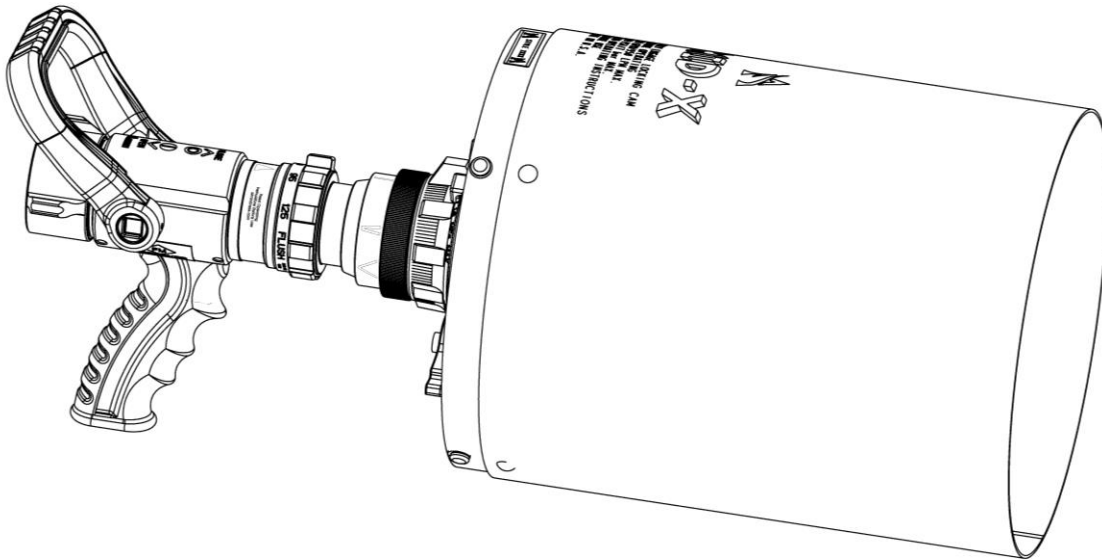

STYLE 0866 Mid-X™ Foam Tube INSTALLATION, OPERATING, AND MAINTENANCE INSTRUCTIONS

The following is intended to provide the basic instructions for installation, operation, and maintenance. Read and understand these operating instructions before use.





STYLE 0866 Mid-X™ Foam Tube INSTALLATION, OPERATING, AND MAINTENANCE INSTRUCTIONS



Read and follow the operating instructions before use.



For firefighting use only.

Product Ratings

Style 0866 Mid-X™ Foam Tube

- Use on 1-1/2" (38mm) Turbojet nozzles
- This includes Styles: 1714, 1715, 1716, 1717, 1718, 1720
- 100psi (7bar) maximum operating pressure
- 250GPM (950LPM) maximum flow

Product Warnings



- Indicates a hazardous situation which, if not avoided, WILL result in death or serious injury.



- Indicates a hazardous situation which, if not avoided, COULD result in death or serious injury.



- Indicates a potentially hazardous situation which, if not avoided, may result in minor or moderate injury.



- Addresses practices not related to personal injury.



- Not for use on electrical fires.



- Lack of foam can place the nozzle operator at risk of injury or death. Establish foam flow before advancing into hazardous situations. Assure against running out of foam. Check concentrate level periodically and keep an adequate supply on hand.



- Improper use of foam can result in injury or damage to the environment. Follow foam concentrate manufacturer's instructions and fire service training to avoid:
 - Using wrong type of foam on a fire, i.e. Class A foam on a Class B fire
 - Mishandling of concentrates, some of which are flammable.
 - Plunging foam into pools of burning liquid fuels.
 - Causing environmental damage.
 - Directing foam into face.



- Each style of foam tube is designed for a specific nozzle. Do not use with other than the intended nozzle. Use with other than the intended nozzle can result in improper latching, poor foam performance, injury or loss of property.



- Any alterations to the Quick-Attack™ foam tube or it's markings constitutes a misuse of these products and could diminish safety.



- Fully engage tabs before flowing.



- Do not operate in wide fog.



STYLE 0866 Mid-X™ Foam Tube INSTALLATION, OPERATING, AND MAINTENANCE INSTRUCTIONS

Attachment to nozzle

To attach the 866 foam tube to the Turbojet nozzle, slide the tube onto the nozzle pattern sleeve. Once onto the nozzle, ensure that the foam tube is centered on the nozzle evenly. Once in place, engage the cam lever to firmly grip the nozzle. Verify that the tube does not move, or wobble and the cam is securely engaged.

Remove from Nozzle

To remove the foam tube from the nozzle, disengage the cam and pull the foam tube off of the nozzle pattern sleeve.

Operating Instructions

- Foam quality is controlled by the position of the nozzle pattern sleeve and the corresponding stream shape.
- Straight stream position of the nozzle pattern sleeve will result in longer reach but less expansion of the foam solution.
- Narrow fog position of the nozzle pattern sleeve will result in shorter reach but more expansion of the foam solution.
- Foam tubes should not be operated with the nozzle pattern sleeve in the wide fog position.

Maintenance Instructions

- After use, flush the nozzle and foam tube with clean fresh water to clean foam concentrate, grit and dirt from around interior and exterior moving parts. Doing so will allow the nozzle and foam tube to operate as designed.

Warranty Statement

WARRANTY AND DISCLAIMER*: We warrant Akron Brass products for a period of five (5) years* after purchase against defects in materials or workmanship. Akron Brass will repair or replace product which fails to satisfy this warranty. Repair or replacement shall be at the discretion of Akron Brass. Products must be promptly returned to Akron Brass for warranty service. We will not be responsible for: wear and tear; any improper installation, use, maintenance or storage; negligence of the owner or user; repair or modification after delivery; failure to follow our instructions or recommendations; or anything else beyond our control. WE MAKE NO WARRANTIES, EXPRESS OR IMPLIED, OTHER THAN THOSE INCLUDED IN THIS WARRANTY STATEMENT, AND WE DISCLAIM ANY IMPLIED WARRANTY OF MERCHANTABILITY OR FITNESS FOR ANY PARTICULAR PURPOSE. Further, we will not be responsible for any consequential, incidental or indirect damages (including, but not limited to, any loss of profits) from any cause whatsoever. No person has authority to change this warranty. Unless otherwise provided herein. Akron Brass industrial electronic components & the Severe-Duty Monitor have a one (1) year warranty. Select Akron Brass handline nozzles and valves carry a ten (10) year warranty. Weldon products have a two (2) year warranty from date of manufacture (excluding consumable components). Select Weldon LED products carry a five (5) year warranty. Honda products have the manufacturers' warranty and Akron Brass disclaims any warranty in respect of those products.



**STYLE 0866 Mid-X™ Foam Tube
INSTALLATION, OPERATING, AND MAINTENANCE INSTRUCTIONS**

Revision History

Revision	Reason Updated