

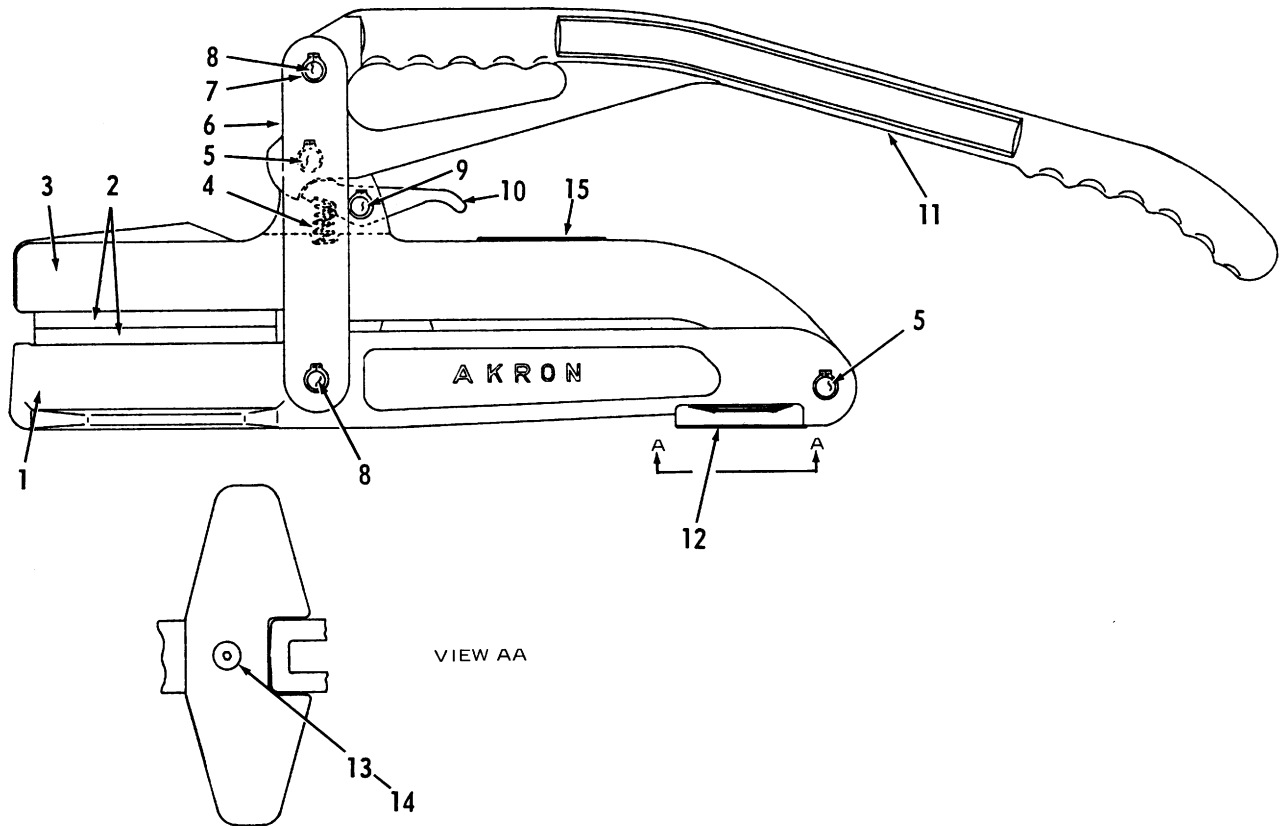

AKRON[®]
BRASS COMPANY

STYLE 588 and 589
Hose Clamp and Mounting Bracket

TECHNICAL SERVICE PARTS LIST





**STYLE 588 and 589
Hose Clamp and Mounting Bracket
TECHNICAL SERVICE PARTS LIST**

ITEM NO.	DESCRIPTION	PART NUMBER	QUANTITY
1	Lower Jaw/Base	0588-0005	1
2	Jaw Liner	7-29-113	2
3	Upper Jaw/Clamping Arm	0588-0006	1
4	Spring	7-68-171	1
5	Pin	101742	2
6	Toggle Arm	7-02-081	2
7	Retaining Ring	7-58-015	10
8	Toggle Arm Pin	101741	2
9	Safety Clamp Pin	101743	1
10	Safety Latch	101745	1
11	Handle	0588-0003	1
12	Foot Plate	0588-0004	1
13	Lock Washer	7-84-026	1
14	Flat Head Screw	7-65-031	1
15	Warning Tag	7-73-137	1
*	Bracket Spring Clip	7-68-084	1
*	Bracket Base	Not sold separately	1

* Style 589 Hose Clamp Mounting Bracket not shown.



ISO 9001 REGISTERED COMPANY

PHONE: 330.264.5678 or 800.228.1161 | FAX: 330.264.2944 or 800.531.7335 | www.akronbrass.com
Available in Canada through AKRON MANUFACTURING COMPANY
PHONE: 519.773.8431 | FAX: 519.773.3794

AB-518 (REV. 03/00)

WARRANTY AND DISCLAIMER: We warrant Akron Brass products for a period of five (5) years after purchase against defects in materials or workmanship. Akron Brass will repair or replace product which fails to satisfy this warranty. Repair or replacement shall be at the discretion of Akron Brass. Products must be promptly returned to Akron Brass for warranty service.
We will not be responsible for: wear and tear; any improper installation, use, maintenance or storage; negligence of the owner or user; repair or modification after delivery; damage; failure to follow our instructions or recommendations; or anything else beyond our control. WE MAKE NO WARRANTIES, EXPRESS OR IMPLIED, OTHER THAN THOSE INCLUDED IN THIS WARRANTY STATEMENT, AND WE DISCLAIM ANY IMPLIED WARRANTY OF MERCHANTABILITY OR FITNESS FOR ANY PARTICULAR PURPOSE. Further, we will not be responsible for any consequential, incidental or indirect damages (including, but not limited to, any loss of profits) from any cause whatsoever. No person has authority to change this warranty.

© Premier Farnell Corporation. 2000 All rights reserved. No portion of this can be reproduced without the express written consent of Premier Farnell Corporation.

A Premier Farnell Company