

**TECHNICAL SERVICE PARTS LIST**

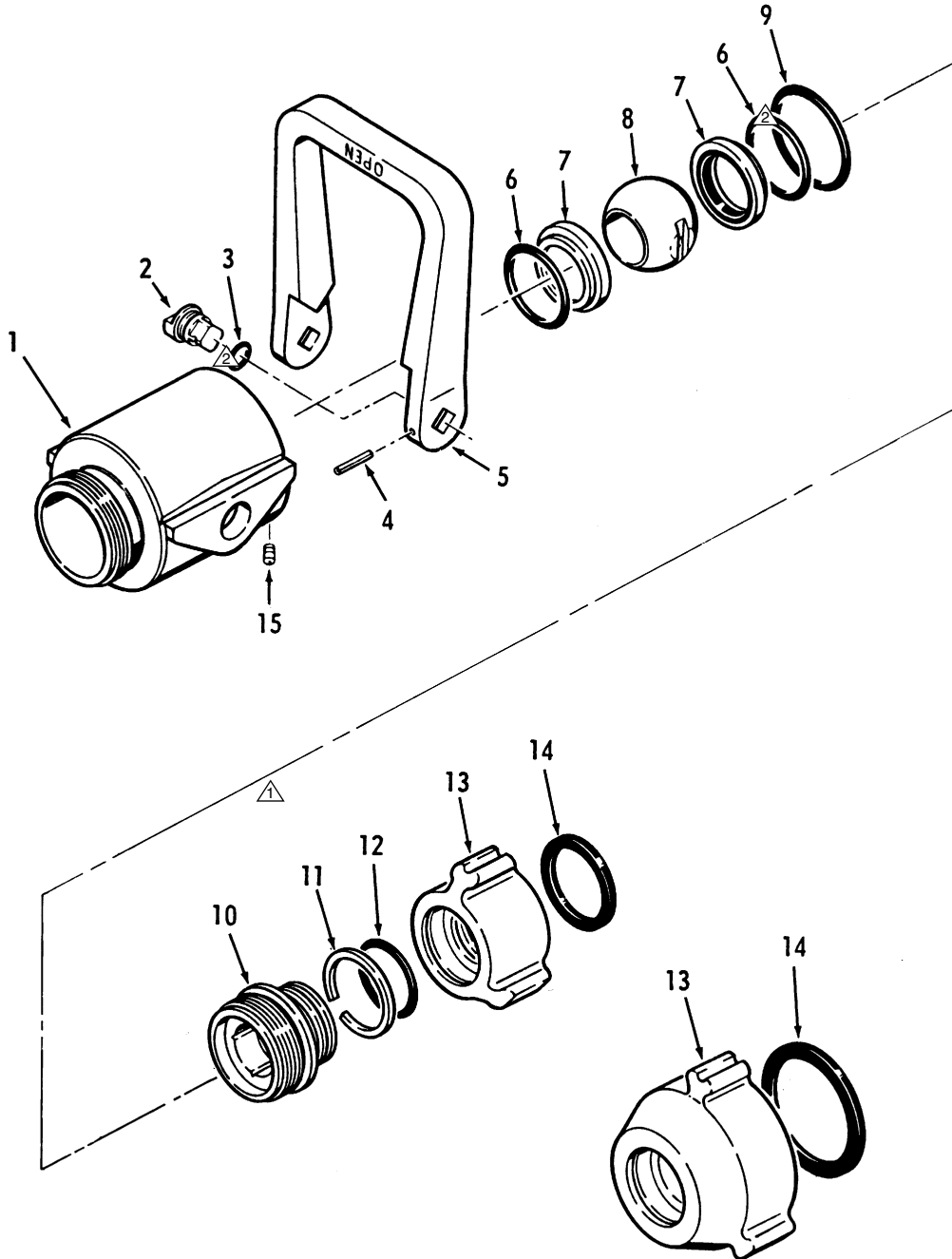

**ASSEMBLY NOTES:**

- ▲ Use Loctite 222  
or Permabond LM 113
- ▲ Use Parker O-Ring  
lubricant or equivalent  
petroleum base lubricant



# STYLES 1125 and 1128 Ball Shutoffs TECHNICAL SERVICE PARTS LIST

ITEM NO.	DESCRIPTION	PART NUMBER	QUANTITY	
			1125	1128
1	Shutoff Body CP (NH) †	101924	1	1
1	Shutoff Body Cast (NH) †	101921	1	1
2	Trunnion CP	102291	2	2
2	Trunnion Cast	7-73-110	2	2
3	O-Ring	7-57-022	2	2
4	Roll Pin	7-44-062	2	2
5	Handle	7-21-123	1	1
6	O-Ring	7-57-060	2	2
7	Seat	7-69-243	2	2
8	Ball	7-04-029	1	1
9	O-Ring	7-57-150	1	1
10-13	Swivel Sub Assembly (NH) CP †	1722-0010	1	
10-13	Swivel Sub Assembly (NH) Cast †	1722-0001	1	
10-13	Swivel Sub Assembly (NPSH) CP †	1722-0011	1	
10-13	Swivel Sub Assembly (NPSH) Cast †	1722-0002	1	
10-13	Swivel Sub Assembly (NH) CP †	1725-0019		1
10-13	Swivel Sub Assembly (NH) Cast †	1725-00-0-2-81-001		1
14	Swivel Gasket	7-17-042	1	
14	Swivel Gasket	7-17-043		1
15	Set Screw	7-65-008	1	1

† For other threads order by description and thread size (ODM and TPI)



ISO 9001 REGISTERED COMPANY

PHONE: 330.264.5678 or 800.228.1161 | FAX: 330.264.2944 or 800.531.7335 | [www.akronbrass.com](http://www.akronbrass.com)  
Available in Canada through AKRON MANUFACTURING COMPANY  
PHONE: 519.773.8431 | FAX: 519.773.3794

AB-383 (REV. 1/99)

**WARRANTY AND DISCLAIMER:** We warrant Akron Brass products for a period of five (5) years after purchase against defects in materials or workmanship. Akron Brass will repair or replace product which fails to satisfy this warranty. Repair or replacement shall be at the discretion of Akron Brass. Products must be promptly returned to Akron Brass for warranty service.  
We will not be responsible for: wear and tear; any improper installation, use, maintenance or storage; negligence of the owner or user; repair or modification after delivery; damage; failure to follow our instructions or recommendations; or anything else beyond our control. **WE MAKE NO WARRANTIES, EXPRESS OR IMPLIED, OTHER THAN THOSE INCLUDED IN THIS WARRANTY STATEMENT, AND WE DISCLAIM ANY IMPLIED WARRANTY OF MERCHANTABILITY OR FITNESS FOR ANY PARTICULAR PURPOSE.** Further, we will not be responsible for any consequential, incidental or indirect damages (including, but not limited to, any loss of profits) from any cause whatsoever. No person has authority to change this warranty.

© Premier Farnell Corporation. 2000 All rights reserved. No portion of this can be reproduced without the express written consent of Premier Farnell Corporation.

**A Premier Farnell Company**