

NOTE: This product model is no longer in production. For service and repair, please contact Akron's Customer Service at 800.228.1161 or 330.264.5678.

STYLE 3070, 3071
Brass Educator

TECHNICAL SERVICE PARTS LIST

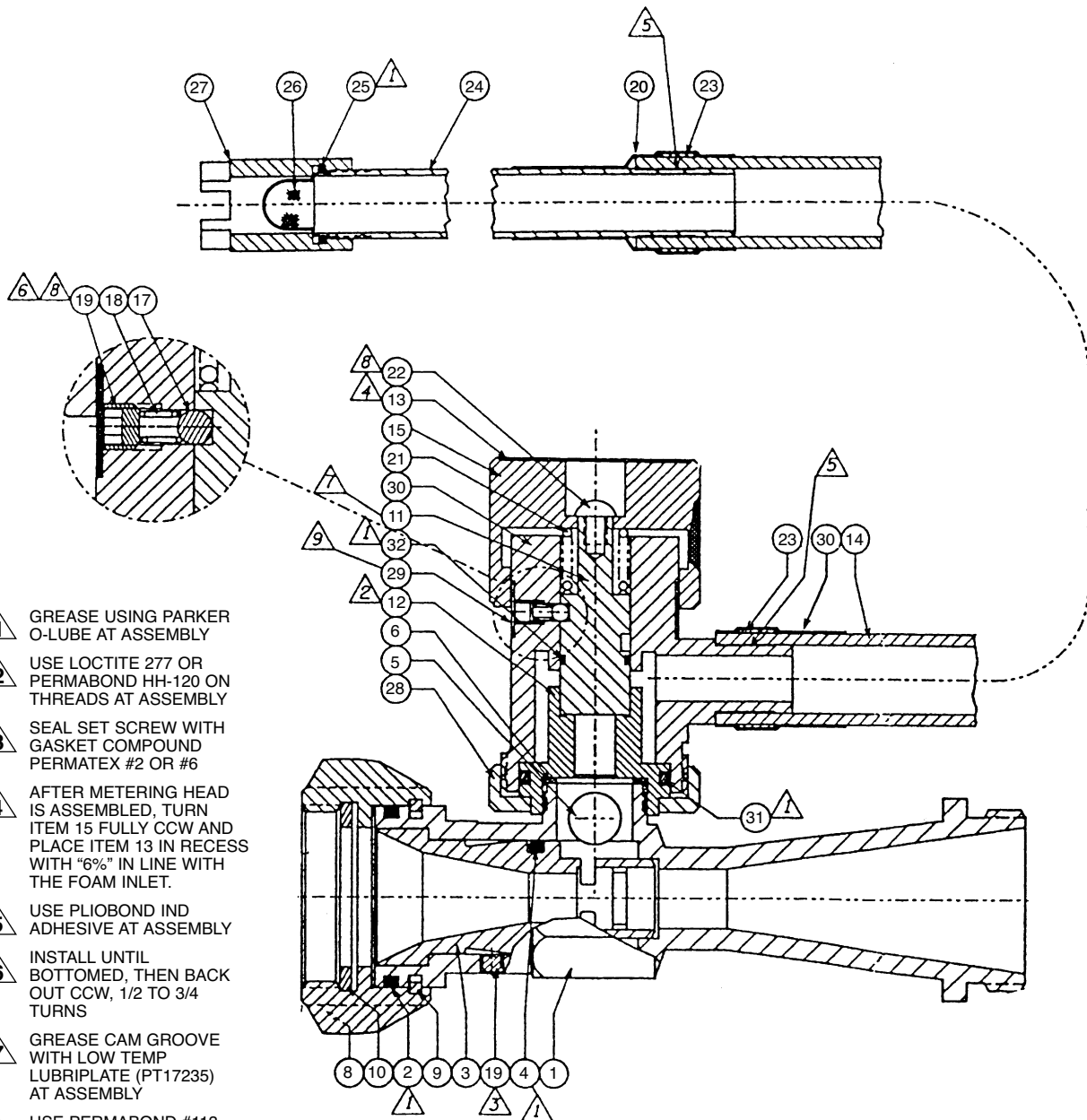

- ① GREASE USING PARKER O-LUBE AT ASSEMBLY
- ② USE LOCTITE 277 OR PERMABOND HH-120 ON THREADS AT ASSEMBLY
- ③ SEAL SET SCREW WITH GASKET COMPOUND PERMATEX #2 OR #6
- ④ AFTER METERING HEAD IS ASSEMBLED, TURN ITEM 15 FULLY CCW AND PLACE ITEM 13 IN RECESS WITH "6%" IN LINE WITH THE FOAM INLET.
- ⑤ USE PLIOBOND IND ADHESIVE AT ASSEMBLY
- ⑥ INSTALL UNTIL BOTTOMED, THEN BACK OUT CCW, 1/2 TO 3/4 TURNS
- ⑦ GREASE CAM GROOVE WITH LOW TEMP LUBRIPLATE (PT17235) AT ASSEMBLY
- ⑧ USE PERMABOND #113 OR LOCTITE 222 ON THREADS AT ASSEMBLY
- ⑨ PLACE ITEM 29 IN RECESS WITH INDICATOR IN LINE WITH THE FOAM INLET.



STYLE 3070, 3071
Brass Eductor
TECHNICAL SERVICE PARTS LIST

ITEM NO.	DESCRIPTION	PART NUMBER	3070	3071
1	Eductor Body-60 GPM*	7-04-492	1	-
1	Eductor Body-95 GPM*	7-04-493	-	1
2	O-Ring	7-57-267	1	1
3	Blending Tube-60 GPM	7-72-155	1	-
3	Blending Tube-95 GPM	7-72-156	-	1
4	O-Ring	7-57-010	1	1
5	Check Ball	7-03-159	1	1
6	Gasket	7-16-027	1	1
7	O-Ring	7-57-031	1	1
8	Swivel-1-1/2" NH**	102251	1	1
9	Piston Ring	7-56-003	1	1
10	Swivel Gasket-1-1/2"	7-17-042	1	1
11	Spool	107340	1	1
12	Adapter-60 GPM	107339	1	-
12	Adapter-95 GPM	107338	-	1
13	Dial Label-60 GPM	7-29-221	1	-
13	Dial Label-95 GPM	7-29-220	-	1
14	Pickup Hose	104219	1	1
15	Control Knob	104274	1	1
16	O-Ring	7-57-041	1	1
17	Ball	7-04-018	1	1
18	Spring	7-68-267	1	1
19	Screw	7-65-008	2	2
20	Heat Shrink Tube	7-72-158	2	2
21	Spring	7-69-437	1	1
22	Screw	7-63-067	1	1
23	Clamp	7-07-333	2	2
24	Tube	109423	1	1
25	O-Ring	7-57-009	1	1
26	Strainer	7-69-521	1	1
27	Retainer	109422	1	1
28	Swivel Collar	104942	1	1
29	Ident. Band-60 GPM	7-04-429	1	-
29	Ident. Band-95 GPM	7-04-428	-	1
29	Ident. Band-125 GPM	7-04-427	-	-
30	Body	109361	1	1
31	O-Ring	7-57-055	1	1

* Threads other than 1-1/2 NH will include permanent adapter on discharge end of eductor.
** For other threads order by description and thread size (ODM and TPI) or Akron Thread Code.

To ensure continued quality performance, use only AKRON replacement parts.
In the U.S. - Phone: (800) 228-1161 • Fax: (800) 531-7335



AKRON BRASS
A **PREMIER FARNELL** Company
An ISO 9001 Registered Company

U.S./INTERNATIONAL
AKRON BRASS COMPANY
P.O. Box 86, Wooster, Ohio 44691
(330) 264-5678
FAX # (330) 264-2944

Available in CANADA through
AKRON MANUFACTURING COMPANY
P.O. Box 280, Aylmer, Ontario, N5H 2R9
(519) 773-8431
FAX # (519) 773-3794

WARRANTY AND DISCLAIMER: We warrant Akron Brass products for a period of five (5) years after purchase against defects in materials or workmanship. Akron Brass will repair or replace product which fails to satisfy this warranty. Repair or replacement shall be at the discretion of Akron Brass. Products must be promptly returned to Akron Brass for warranty service.

We will not be responsible for: wear and tear; any improper installation, use, maintenance or storage; negligence of the owner or user; repair or modification after delivery; damage; failure to follow our instructions or recommendations; or anything else beyond our control. **WE MAKE NO WARRANTIES, EXPRESS OR IMPLIED, OTHER THAN THOSE INCLUDED IN THIS WARRANTY STATEMENT, AND WE DISCLAIM ANY IMPLIED WARRANTY OF MERCHANTABILITY OR FITNESS FOR ANY PARTICULAR PURPOSE.** Further, we will not be responsible for any consequential, incidental or indirect damages (including, but not limited to, any loss of profits) from any cause whatsoever. No person has authority to change this warranty.

Home-page: www.akronbrass.com; E-mail: custserv@akronbrass.com

AB-419 (REV. 4/99) PRINTED IN U.S.A.
ORR. PRINTING - 9731

©Copyright 1999 by Premier Farnell Corp.

®Registered Trademark of Premier Farnell Corp.
™Trademark of Premier Farnell Corp.

All rights reserved. No portion of this publication, whether in whole or in part, can be reproduced without the express written consent of Premier Farnell Corp.