

**NOTE: This product model is no longer in production. For service and repair, please contact Akron's Customer Service at 800.228.1161 or 330.264.5678.**

**STYLE 3061, 3096, 3126  
Truck By-Pass Eductor Metering Panel  
Built Prior to March 1, 2000**

**TECHNICAL SERVICE PARTS LIST**

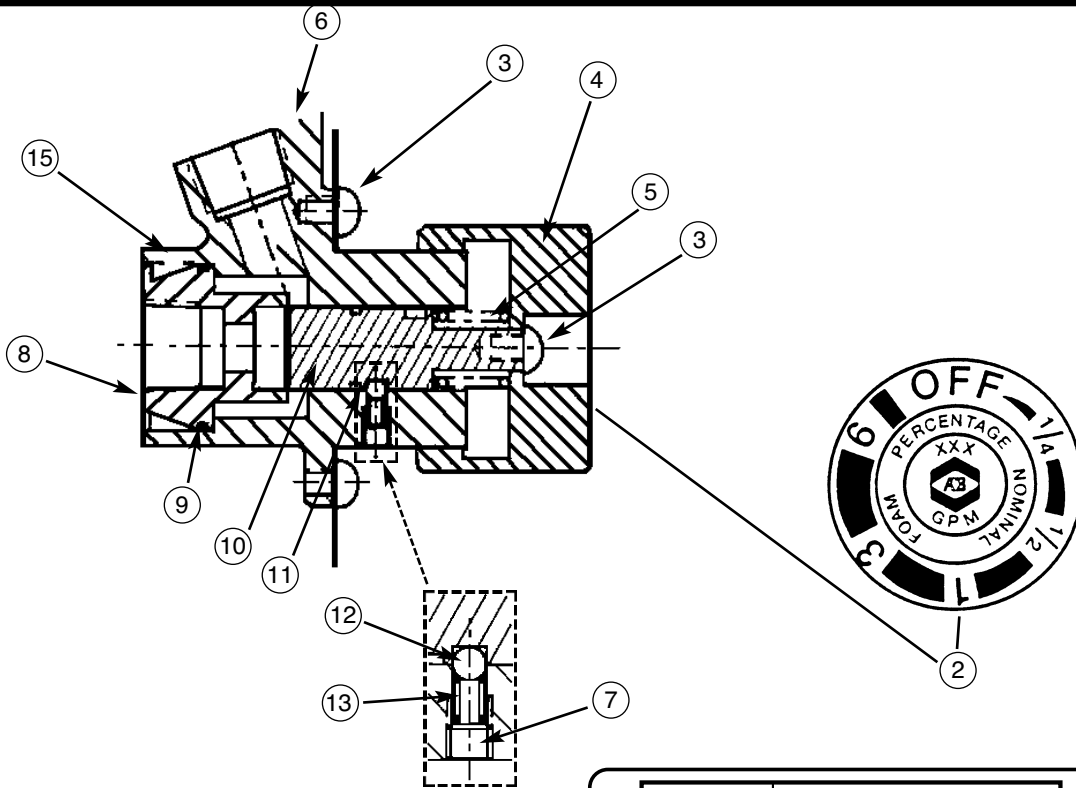

VALVE	VALVE POSITION FOR		
	FOAM	WATER ONLY	FLUSH (3 MIN)
WATER	OPEN	OPEN	OPEN
EDUCTOR	OPEN (200 PSI)	CLOSE	OPEN (100 PSI)
FOAM	OPEN	CLOSE	CLOSE
FLUSH	CLOSE	CLOSE	OPEN

**CLASS A/B**  
 SELECT PERCENT  
 GPM  
 F O A M  
 SYSTEM

**Akron®**

- EDUCTOR PRESSURE - 200 psi
- USE AKRON XXX gpm NOZZLE
- MAXIMUM HOSE LAYS: { XX" HOSE - XXX FEET (XXX FEET UP TO 1%)  
XX" HOSE - XXX FEET

BASED ON MAX. NOZZLE ELEVATION OF 10 FT. ABOVE EDUCTOR  
 CAUTION: SEE OPERATION INSTRUCTIONS BEFORE USE



**STYLE 3061, 3096, 3126**  
**Truck By-Pass Eductor Metering Panel**  
**Built Prior to March 1, 2000**  
**TECHNICAL SERVICE PARTS LIST**

ITEM NO.	DESCRIPTION	PART NUMBER	QUANTITY		
			3061	3096	3126
1	Escutcheon Plate – 60 GPM	7-42-117	1	-	-
1	Escutcheon Plate – 95 GPM	7-42-116	-	1	-
1	Escutcheon Plate – 125 GPM	7-42-109	-	-	1
2	Dial Label – 60 GPM	7-29-221	1	-	-
2	Dial Label – 95 GPM	7-29-220	-	1	-
2	Dial Label – 125 GPM	7-29-219	-	-	1
3	Screw	7-63-067	3	3	3
4	Dial	7-27-042	1	1	1
5	Spring	7-69-437	1	1	1
6	Housing	109391	1	1	1
7	Screw	7-65-008	1	1	1
8	Adapter	107344	1	-	-
8	Adapter	107343	-	1	1
9	O-Ring	7-57-066	1	1	1
10	Metering Spool	115414	1	1	1
11	O-Ring	7-57-055	1	1	1
12	Ball	7-04-018	1	1	1
13	Spring	7-68-267	1	1	1
14*	Adapter	7-02-062	2	2	2
15	Screw	7-65-047	1	1	1
-	Washer (not shown)	7-84-064	1	1	1

\*No longer supplied with assembly. Available on request.



PHONE: 330.264.5678 or 800.228.1161 | FAX: 330.264.2944 or 800.531.7335 | [www.akronbrass.com](http://www.akronbrass.com)  
 Available in Canada through AKRON MANUFACTURING COMPANY  
 PHONE: 519.773.8431 | FAX: 519.773.3794

AB-102 (REV. 03/00)

WARRANTY AND DISCLAIMER: We warrant Akron Brass products for a period of five (5) years after purchase against defects in materials or workmanship. Akron Brass will repair or replace product which fails to satisfy this warranty. Repair or replacement shall be at the discretion of Akron Brass. Products must be promptly returned to Akron Brass for warranty service. We will not be responsible for: wear and tear; any improper installation, use, maintenance or storage; negligence of the owner or user; repair or modification after delivery; damage; failure to follow our instructions or recommendations; or anything else beyond our control. WE MAKE NO WARRANTIES, EXPRESS OR IMPLIED, OTHER THAN THOSE INCLUDED IN THIS WARRANTY STATEMENT, AND WE DISCLAIM ANY IMPLIED WARRANTY OF MERCHANTABILITY OR FITNESS FOR ANY PARTICULAR PURPOSE. Further, we will not be responsible for any consequential, incidental or indirect damages (including, but not limited to, any loss of profits) from any cause whatsoever. No person has authority to change this warranty.

© Premier Farnell Corporation. 2000 All rights reserved. No portion of this can be reproduced without the express written consent of Premier Farnell Corporation.

