



OWNER'S MANUAL

**For Genesis™ Manual-Hydraulic
Power Unit Style 3590**

GENESIS™ STYLE 3590 OWNER'S MANUAL

Introduction

The Akron Brass Genesis Style 3590 Manual Hydraulic Power Unit is designed to provide efficient trouble-free operation for many years. This manual includes all the installation, operating and trouble-shooting instructions normally required to assist in obtaining the best possible performance from this unit.

DO NOT attempt to install, operate or trouble-shoot this unit without first reading the warnings, installation, operating and trouble-shooting sections of this manual.

General Product Description

This Genesis Style 3590 Manual-Hydraulic Power Unit provides manual; remote operation of a hydraulically controlled monitor, by means of a manual hydraulic pump and three function control valves. The unit controls the horizontal, vertical movement of the monitor, plus the pattern of the nozzle. The speed of each function is directly proportional to the stroke rate of the pump handle. The major components of the Genesis Style 3590 power unit include a double-acting hydraulic piston pump, a three spool directional control valve with integral pressure relief, and a 5.4 gallon hydraulic fluid reservoir, all combined into an efficient compact system.

Warning

1. This unit is designed to operate in ambient temperatures of minus 10 degree F (-10 degree F) to plus 140 degree F (140 degree F). DO NOT install this unit in an environment where ambient temperatures of less than minus 10 degree F (-10 degree F) or more than plus 140 degree F (140 degree F) are possible.
2. This unit is equipped with a fixed (non-adjustable) pressure relief valve, set at 1000 psi. DO NOT attempt to make adjustments to this valve.
3. Use only the recommended hydraulic fluids listed in this manual. Use of improper hydraulic fluids can result in poor monitor response especially in cold conditions. Use of improper hydraulic fluids can also result in damage to internal seals leaving the unit inoperative.
4. This size of the interconnect tubing/hose between the monitor and the power unit is a function of the viscosity of the selected hydraulic fluid, the ambient temperature, and the distance between the units. If the distance between the monitor and the power unit is less than 100 feet one way; 1/2" diameter tubing is normally sufficient. Distances beyond 100 feet will require a corresponding increase in tubing diameter. If you have questions concerning the determination of the optimum tubing size for your installation, contact Akron Brass for assistance.

Installation And Start-Up

The Akron Brass Manual-Hydraulic Power Unit is delivered preassembled and tested to assure ease of installation and operation. A mounting bracket is also included which will securely attach the power unit to a 4" to 6" diameter standpipe. After attaching the mounting bracket to a suitable standpipe, and the power unit to the bracket; as shown in the accompanying installation drawing, the customer supplied hydraulic interconnect piping which runs between the power unit and the monitor can be installed. Again, referring to the installation drawing, connect piping between ports as shown ("A" to "A", "B" to "B" etc.). Ensure that all pipe fittings which terminate at the power unit or monitor are of the proper type and size (o-ring, NPT etc.).

After the system is installed and piping interconnections are completed the power unit reservoir should be filled to the top with the proper grade of hydraulic fluid. (See the specifications sections of this manual for recommended hydraulic fluids.)

Prior to placing the unit into operation, all entrapped air must be purged from the system. This can be accomplished by completing each of the following steps for each of the six hydraulic lines. Remember, purge only one line at a time.

1. Shift the function control lever, located on the valve bank, to the "on" position for the line which is to be purged.
2. Go to the highest hydraulic connection for that line (usually at the monitor) and disconnect it.
3. Using a suitable container to catch oil from the disconnected line, have an assistant pump the hand pump lever until a solid stream (no air bubbles) of hydraulic fluid is pumped into the can. During this process, have the assistant monitor the level of the hydraulic fluid in the reservoir. If the fluid level drops below the bottom level of the sight glass stop and refill the reservoir before continuing.
4. Once a solid stream of oil is observed coming from the disconnected pipe, stop the process, reconnect the pipe and repeat this procedure with the pipe of the functions opposite member, i.e.; do both pipes for the rotation function before moving onto the elevation or pattern functions.
5. Repeat steps 1-4 for the remaining two functions.

After the entire purging process is complete, ensure that all connections are tight and leak free. Remove or add hydraulic fluid to reservoir as required to maintain a level which is approximately 2/3 up the sight glass

Note:

As a final check, operate each function independently to assure that the actual monitor movement matches the function template mounted on the power unit.

Operating Principles

Operation is accomplished by shifting one of the control valve levers to the desired operating position as shown on the operating template located on the top of the power unit, and moving the pump handle in a forward and backward motion. Only one function should be operated at a time. The speed at which the monitor operates is directly proportional to the stroke rate of the pump handle. The optimum stroke rate for the pump is approximately 100 to 120 full cycles per minute. When the desired monitor function's position is reached, the control valve lever should be returned to the neutral or center position.

Trouble-shooting

Problem	Solution
1. Pump handle moves freely but no movement can be accomplished on any monitor function.	a. Check oil level in reservoir, if ok, go to (b).
	b. Air is probably present in the system. Repeat start-up procedure.
	c. If problem still exists, check relief valve cavity for foreign material, clean and reinstall.
	d. If problem still exists, disassemble pump and inspect for damaged seals. Repair or replace as required.
2. One or two functions work fine, but other function does not respond.	a. Take lines loose from monitor end of function that does not respond. Plug them and shift control lever and pump as usual; if system now builds pressure, the problem is in the drive motor. Inspect and repair or replace as needed.

Periodic Maintenance

To ensure proper operation, the following periodic maintenance activities should be completed monthly.

Check for proper oil level in the reservoir. Ensure that no water has entered the reservoir.

Operate all three functions (monitor rotation, elevation and nozzle pattern) through their range of motion.

Check hoses and fittings, both on the power unit and monitor for leaks.

To ensure proper operation, the following periodic maintenance activities should be completed annually.

Clean old grease from exposed gears and apply a new layer of Lubri-Plate low temperature grease.

Apply Lubri-Plate low temperature grease to the grease fittings located on the monitor.

Specifications

Pump:

- Type — double acting piston pump
- Displacement — 1.5 in. 3/full cycle
- Stroke rate — 120 full cycles/min = 3/4 gpm
- Maximum operating pressure — 2000 psi
- Handle length — 24"
- Handle force — 39 lbs. @ 1000 psi pump pressure
- Material — stainless steel and aluminum bronze

Valve:

Type — Directional, double — acting spool type
Spools — 3
Maximum operating pressure — 2000 psi
Relief — 1000 psi fixed (non adjustable)
Material — cast steel

Reservoir:

Capacity — 5.4 gallons
Material — stainless steel

General:

Operating temperature — -10 degree F to +140 degree F.
Operating pressure — 1000 psi maximum
Power unit dimensions 20" long X 15" wide X 213/8" w/o handle
Mounting bracket dimensions 18" long X 191/2" wide X 13" high
Power unit weight — 66 lbs. — without hydraulic fluid
Mounting bracket weight — 40 lbs.

Inter-connect Tubing/Fitting/Fluid SpecificationsInterconnect Tubing between the Monitor and HPU:

1/2" OD with a 0.035" minimum wall thickness, per the following specification:

Fully annealed high quality (Type 304 or 316) stainless steel hydraulic tubing ASTM A269 or A213 or equivalent, seamless or welded and drawn with a hardness of Rb80 or less. Tubing should be without scratches and suitable for flaring bending.

Hydraulic Monitor Fittings:

Rotation Function:

(2) 9/16"-18 O-Ring, female

Elevation and Nozzle Function:

(4) 1/8" NPT, female

Hydraulic Power Unit Fittings:

All functions:

(6) 1/2" NPT, female

Hydraulic Fluid:

Temperatures from +10° F to +140° F (-12°C to +60°C)- SAE 10W30

Temperatures from +40° F to +140° F (-40°C to +60°C) Amsoil ATF or Dextron III ATF or Equivalent

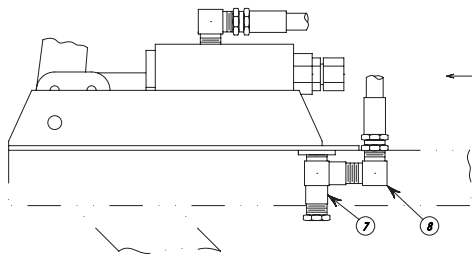
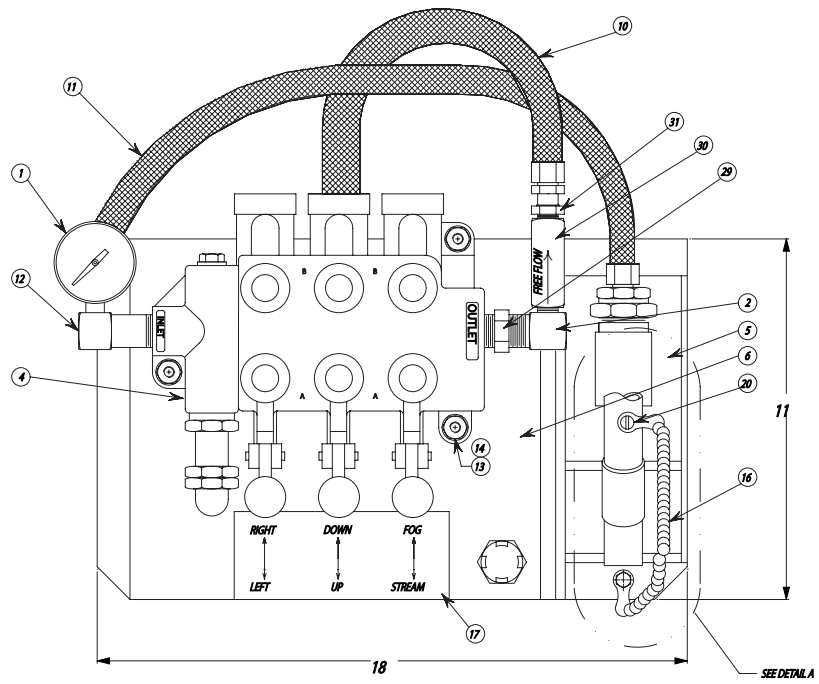

VIEW 'B'

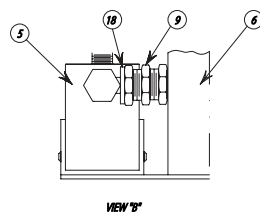

8-32 UNC TIP
THRU ONE SIDE

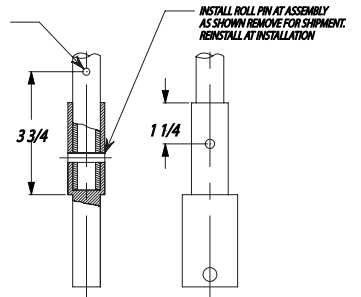

INSTALL ROLL PIN AT ASSEMBLY
AS SHOWN REMOVE FOR SHIPMENT.
REINSTALL AT INSTALLATION

DETAIL 'A'

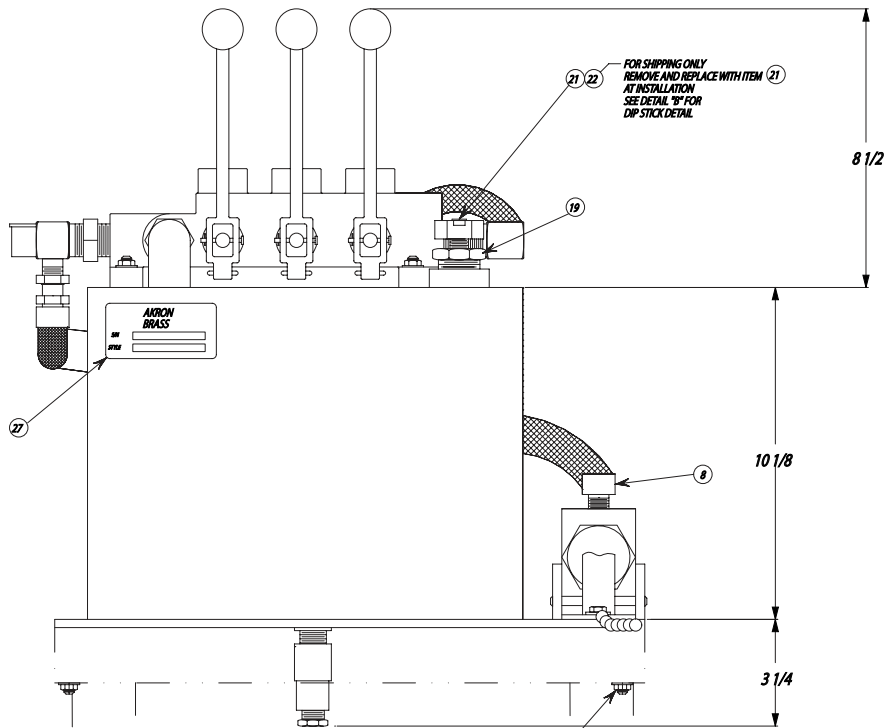

FOR SHIPPING ONLY
REMOVE AND REPLACE WITH ITEM 21
AT INSTALLATION
SEE DETAIL 'B' FOR
DIP STICK DETAIL

NOTE:
UNIT TO BE PRIMED FIRST
AND THEN PAINTED WITH 'AKRON BRASS RED'
EPOXY PAINT. (SEE SHEET 2)

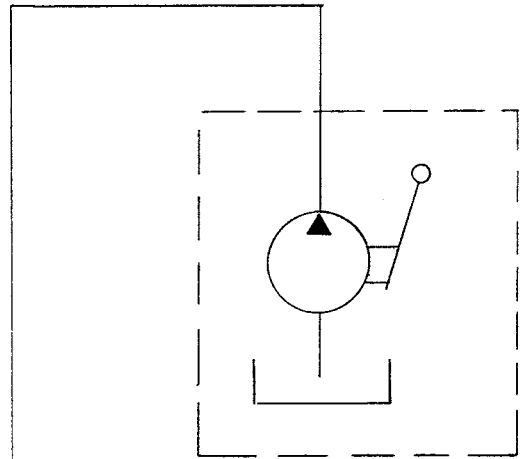
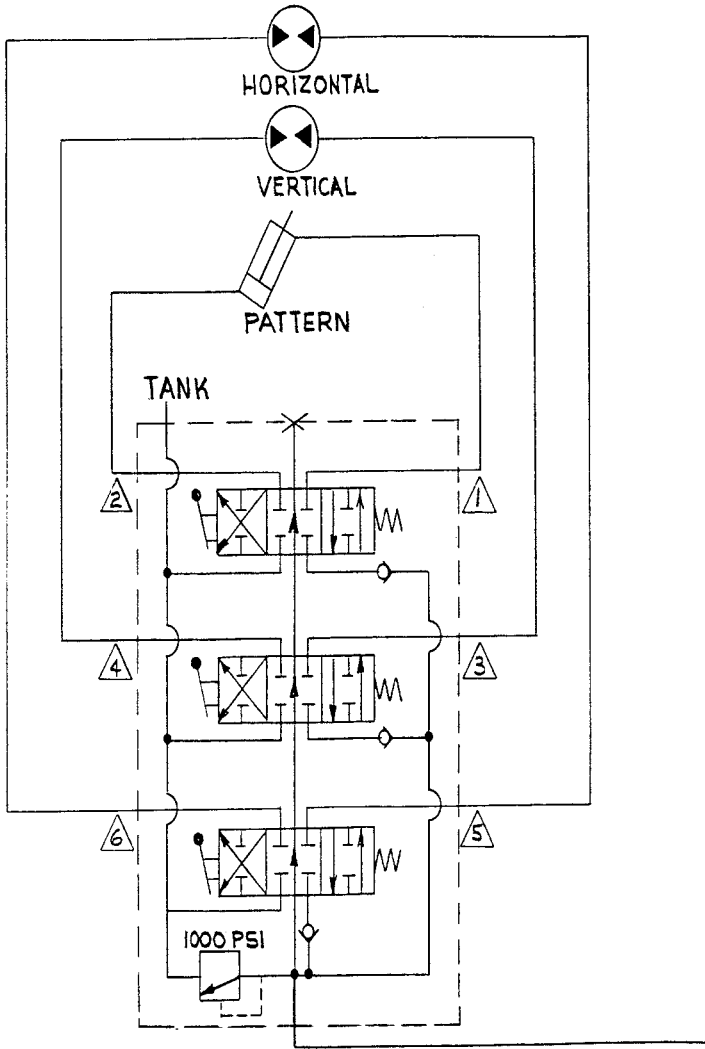

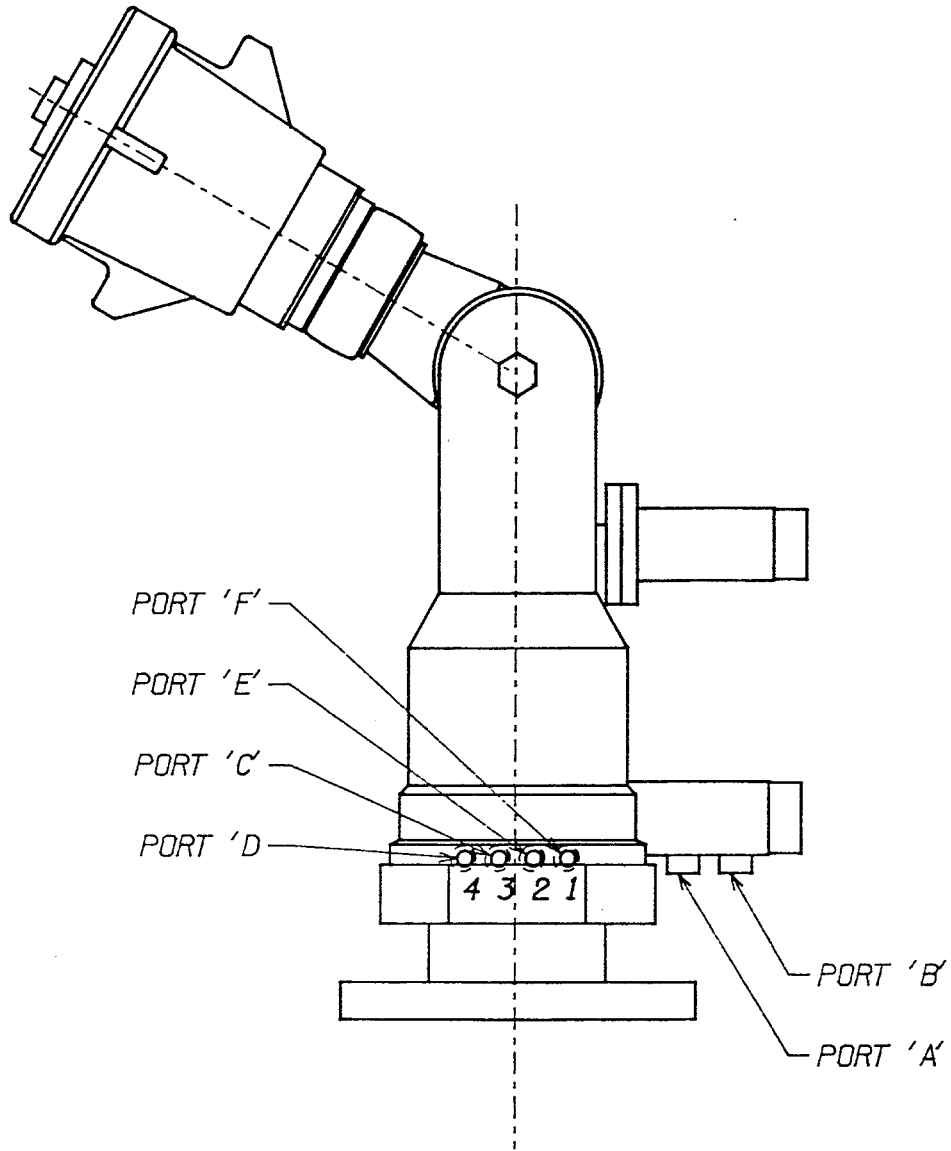

UNITS WITH MANUAL CONTROL VALVES

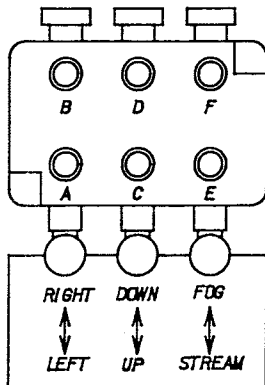

UNITS WITH ELECTRIC SOLENOID CONTROL VALVES

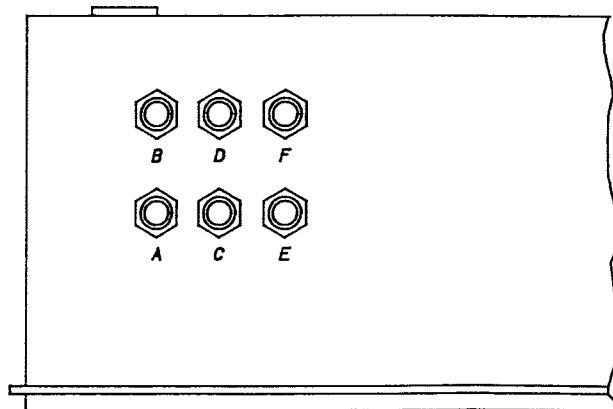



PHONE: 330.264.5678 or 800.228.1161 | FAX: 330.264.2944 or 800.531.7335 | www.akronbrass.com

REVISED: 7/08

WARRANTY AND DISCLAIMER: We warrant Akron Brass products for a period of five (5) years after purchase against defects in materials or workmanship. Akron Brass will repair or replace product which fails to satisfy this warranty. Repair or replacement shall be at the discretion of Akron Brass. Products must be promptly returned to Akron Brass for warranty service.

We will not be responsible for: wear and tear; any improper installation, use, maintenance or storage; negligence of the owner or user; repair or modification after delivery; damage; failure to follow our instructions or recommendations; or anything else beyond our control. WE MAKE NO WARRANTIES, EXPRESS OR IMPLIED, OTHER THAN THOSE INCLUDED IN THIS WARRANTY STATEMENT, AND WE DISCLAIM ANY IMPLIED WARRANTY OF MERCHANTABILITY OR FITNESS FOR ANY PARTICULAR PURPOSE. Further, we will not be responsible for any consequential, incidental or indirect damages (including, but not limited to, any loss of profits) from any cause whatsoever. No person has authority to change this warranty.

© Premier Farnell Corporation. 2000 All rights reserved. No portion of this can be reproduced without the express written consent of Premier Farnell Corporation.

A Premier Farnell Company