



## **AKRON BUMPER TURRET STYLE 3466 12/24 VOLT DC Installation, Operating, and Maintenance Instructions**

### **INTENDED USE**

The Bumper Turret is designed to operate mounted on a vehicle with a 12/24 VDC electrical system. The vehicle system must be capable of providing 85-120 PSI air pressure to operate the vertical and pattern control movement of the turret.

Operation of the turret is generally controlled from a remote location (inside the cab) with a joystick control box.

The following instructions are provided to assist in obtaining the best possible performance from the unit. Read and understand the instructions before proceeding.

### **PRODUCT RATINGS**

MASS: Turret - 35 lbs. (15.9 Kg) Control Box - 10 lbs. (4.5 Kg)  
MAXIMUM FLOW: 500 gpm (1900 lpm)  
MAXIMUM PRESSURE: 250 psi (1724 kPa - 17.2 bar)  
PIPE CONNECTION: 2" victaulic

### **INSTALLATION**

The Akron Style 3466 Bumper Turret is intended to be installed in the opening located on the front of the vehicle cab below the windshield. Eighteen holes are provided in the 1/4" thick Mounting Plate for attachment to the corresponding holes located around the outside circumference of the opening located on the front of the vehicle cab.

The Turret Water Inlet mates with a standard 2" Victaulic coupling. A 1/8" NPT opening with plug is located at the base of the Turret near the inlet. This opening is provided to attach a temporary gauge to determine the Turret inlet pressure, if required.

A single air inlet port is mounted on the air regulator which is located on the inside of the Mounting Plate, above the Turret water inlet. A label is provided to designate this air inlet port. A 1/4" O.D. nylon hose is required to supply air to the Turret at this location. An air supply between 85 and 150 PSI is required for best Turret operation.

A wiring harness is supplied with the Turret. One end of the wiring harness is hard wired directly to the Turret and located inside the Mounting Plate. A 15 Pin Connector and a 2 Pin Connector are attached to the opposite end of the wiring harness. The 15 Pin Connector mates into the bottom of the Joystick Control Box. The 2 Pin Connector mates with an Amp Mate - N - Lock 2 pin housing, part number 1-480319-0. Pin number one is water discharge and pin number two is 12/24 volt DC positive. A 1/4" ring terminal, Amp part number 34150, is provided at the 2 Pin Connector for grounding. A 1/4" bolt is required to secure the ring terminal to the desired ground location.

The Joystick Control Box is designed with four drilled and tapped holes for mounting inside the cab. The holes are 5/16" - 18 UNC threads and are located on the bottom of the control box.

## **OPERATION**

The Turret is controlled from inside the vehicle cab by using the Joystick Control Box. Power to the Turret is activated by turning the vehicle ignition to the "on" position. A light on the Joystick Control Box will indicate the Turret is ready for operation.

The Discharge Control Switch is located on the front of the Joystick. This Discharge Control Switch is a dead-man type; i.e. push and hold the switch to turn on the water/foam discharge and release the switch to turn off the water/foam discharge.

A second Discharge Control Switch is located on the Control Box and protected with a switch safety guard. This Discharge Control Switch can be used to activate and maintain water/foam discharge, rather than holding in the Discharge Control Switch on the joystick.

A Rocker Switch is located on the top of the joystick. This Rocker Switch controls the nozzle discharge pattern. The left side of the switch changes the nozzle pattern to the dispersed pattern. The right side of the switch changes the nozzle pattern to straight stream. An operation guide is provided on the Control Box to the right of the joystick for the Nozzle Pattern Rocker Switch.

The joystick also controls the vertical and horizontal positioning of the nozzle. To elevate the nozzle, pull back on the joystick. To depress the elevation, push the joystick forward. To rotate the nozzle to the left, move the joystick to the left. To rotate the nozzle to the right, move the joystick to the right. The joystick will control the positioning of the nozzle in both vertical and horizontal at the same time. To elevate the nozzle and rotate it to the right, pull the joystick back to the position between elevation and right; i.e., the 4 o'clock position. To depress the nozzle and rotate it to the right, push the joystick forward between depress and right; i.e., the 2 o'clock position. The same positioning to the left can be accomplished by moving the joystick into the 8 o'clock and 10 o'clock quadrant positions respectively.

The Joystick Control Box has an automatic oscillation feature. To activate automatic oscillation, move the switch marked oscillation to the "on" position. The Turret will immediately begin to rotate within the area selected on the oscillation limit knobs. The two oscillation limit knobs are stacked together. The small knob on top controls the right oscillation limit. The larger knob on the bottom controls the left limit. One pin is located on each knob. These pins allow the oscillation limit to be moved with fingertip control.

Oscillation limits can be set between 180° to 10°. The center of oscillation can be set anywhere between 80° left and right of center. Markings for 45° angles and 90° angles are provided for operating convenience.

The automatic oscillation can be disengaged in two different ways. One is to move the oscillation switch to the "off" position. The second is by moving the joystick to the left or right. The joystick is designed to override the automatic oscillation. To re-activate automatic oscillation, move the switch marked oscillation to the "on" position. The Turret will immediately begin to oscillate within the area selected on the oscillation limit knobs.

The Turret nozzle can be elevated or depressed when automatic oscillation is engaged. The joystick can be pushed forward to depress or pulled back to elevate the nozzle during oscillation. If the joystick is moved to the left or right during automatic oscillation, the automatic oscillation will be disengaged.

The nozzle pattern can be changed from straight stream to fully dispersed or from fully dispersed to straight stream during automatic oscillation. The nozzle pattern rocker switch on the top of the joystick operates the same during automatic oscillation or joystick operation.

The Joystick Control Box has a horizontal speed control feature. The horizontal speed is controlled by the knob marked horizontal speed. Maximum horizontal speed is achieved when the knob is turned to the right. To decrease the horizontal speed, turn the knob to the left. The horizontal speed control can be used during automatic oscillation or joystick operation.

The vertical speed control is located outside the cab on the outside of the Turret Mounting Plate and is marked with an identification sticker. The vertical speed control is protected with a threaded plug. To adjust the vertical speed control, remove the plug counterclockwise to reach the needle valve. A small screwdriver will be needed to adjust the needle valve. To increase the vertical speed, turn the needle valve screw counterclockwise in increments of 1/8 of a turn. Check the vertical speed by operating the Turret. If more speed is desired, continue to adjust the needle valve in increments of 1/8 of a turn. To decrease the vertical speed, turn the needle valve screw clockwise in increments of 1/8

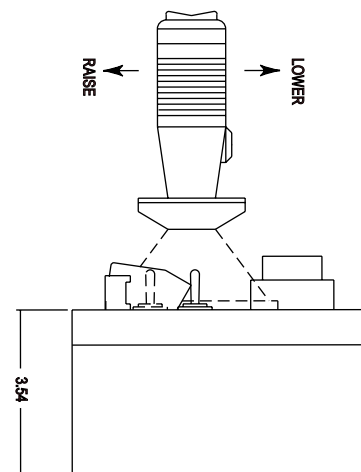
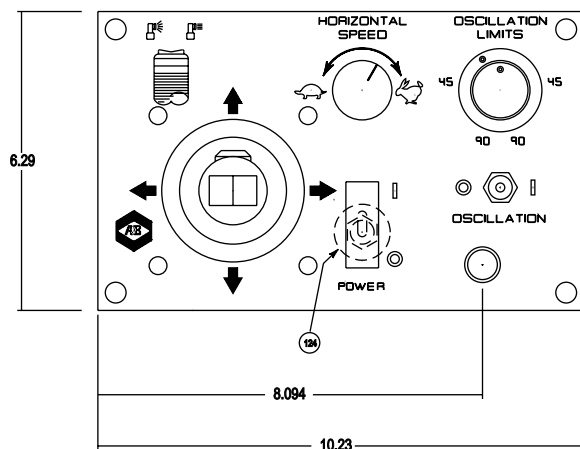
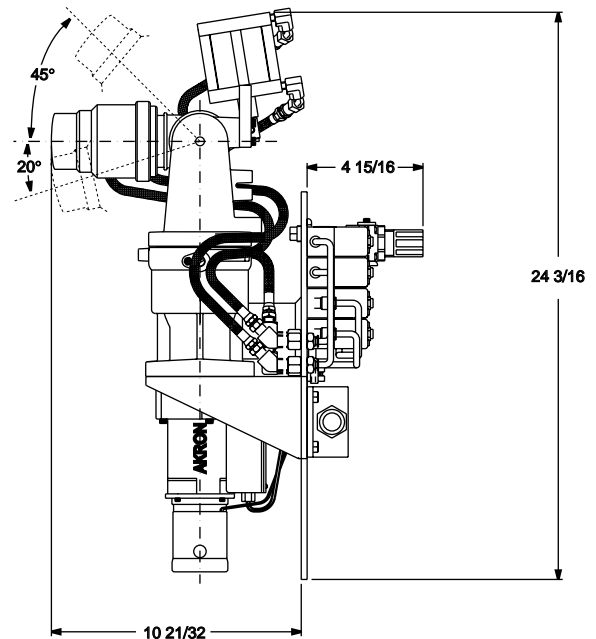
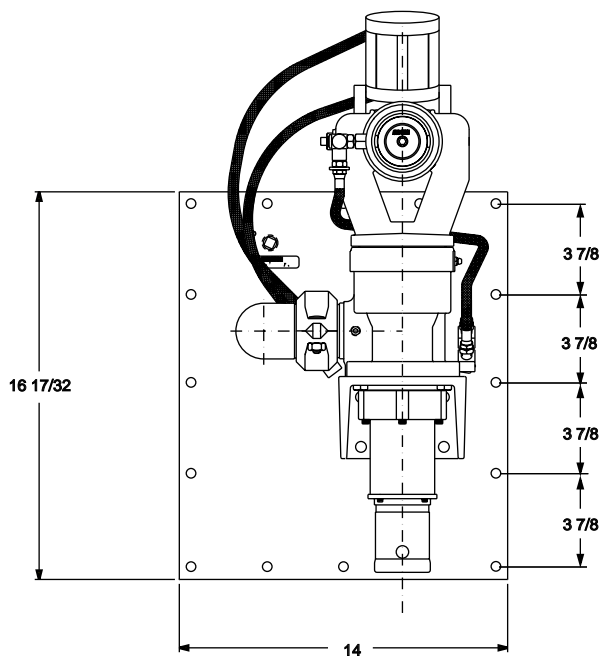

of a turn. Small adjustments of the needle valve screw will change the vertical speed. When vertical speed adjustment is completed, reinstall the plug and tighten with a wrench.

The nozzle pattern speed control is located at the nozzle tip where the air supply lines enter the nozzle pattern sleeve. The nozzle pattern speed control consists of two needle valves, which are adjusted with a small screwdriver when any adjustment to the nozzle pattern speed is made. Both needle valves must be turned the same distance in the same direction. If they are not turned relative to each other, it is possible the nozzle pattern sleeve will drift when the pattern control rocker switch (on the joystick) is released.

The nozzle pattern speed control needle valves are free flowing when the air flows into the nozzle pattern sleeve and restricts the air when it leaves the pattern sleeve. To decrease the speed of the nozzle pattern control, both needle valves must be turned clock wise in increments of 1/8 of a turn. To increase the speed both, needle valves must be turned counterclockwise in increments of 1/8 of a turn.

On Bumper Turrets rated 300 gpm and lower, both needle valves must be turned the same distance in the same direction. If they are not turned relative to each other, it is possible the nozzle pattern sleeve will drift when the pattern control rocker switch (on the joystick) is released. To decrease the speed of the nozzle pattern control, both needle valves must be turned clockwise in increments on 1/8 of a turn. To increase the speed, both needle valves must be turned counterclockwise in increments on 1/8 of a turn.

On Bumper Turrets rated over 300 gpm, the needle valve can be adjusted independent of each other. The needle valve closest to the nozzle discharge controls the speed towards fog. The needle valve closest to air cylinder controls the speed towards straight stream.

## PRODUCT WARNINGS

- △ Warning: For firefighting and other water or approved solution application use only.
- △ Warning: For use by trained personnel only.
- △ Warning: Aim unit in a safe direction before flowing.
- △ Warning: Replace any worn, damaged or missing tags.
- △ Warning: Do not exceed the maximum flow or pressure ratings of the turret. Exceeding these ratings may lead to injury or turret damage.
- △ Warning: Keep all personnel out of the forward zone including 90° left and right sweep area (180°). High pressure flows can cause injury.
- △ Warning: The turret has moving parts. Keep hands, fingers, and objects away from moving parts.

## MAINTENANCE

The Akron Bumper Turret is designed and tested to provide years of durable and reliable operation. The only scheduled maintenance is to lubricate the rotation swivel joint. This maintenance should be completed annually.

To lubricate the rotation swivel joint, first rotate the Turret all the way to the left. Then add one pump of LUBRIPLATE Low Temp™ into the grease fitting using a hand-held manual grease gun. The grease fitting is located on the front of the Turret. Then rotate the Turret all the way to the right and add one more pump of grease.



ISO 9001 REGISTERED COMPANY

PHONE: 330.264.5678 or 800.228.1161 | FAX: 330.264.2944 or 800.531.7335 | [www.akronbrass.com](http://www.akronbrass.com)  
Available in Canada through AKRON MANUFACTURING COMPANY  
PHONE: 519.773.8431 | FAX: 519.773.3794

REVISED 09/02

WARRANTY AND DISCLAIMER: We warrant Akron Brass products for a period of five (5) years after purchase against defects in materials or workmanship. Akron Brass will repair or replace product which fails to satisfy this warranty. Repair or replacement shall be at the discretion of Akron Brass. Products must be promptly returned to Akron Brass for warranty service. We will not be responsible for: wear and tear; any improper installation, use, maintenance or storage; negligence of the owner or user; repair or modification after delivery; damage; failure to follow our instructions or recommendations; or anything else beyond our control. WE MAKE NO WARRANTIES, EXPRESS OR IMPLIED, OTHER THAN THOSE INCLUDED IN THIS WARRANTY STATEMENT, AND WE DISCLAIM ANY IMPLIED WARRANTY OF MERCHANTABILITY OR FITNESS FOR ANY PARTICULAR PURPOSE. Further, we will not be responsible for any consequential, incidental or indirect damages (including, but not limited to, any loss of profits) from any cause whatsoever. No person has authority to change this warranty.

© Premier Farnell Corporation. 2000 All rights reserved. No portion of this can be reproduced without the express written consent of Premier Farnell Corporation.

**A Premier Farnell Company**