



## STYLE 3354 TUCKAWAY™ ELECTRIC MONITOR INSTALLATION, OPERATING, AND MAINTENANCE INSTRUCTIONS

The following is intended to provide the basic instructions for installation, operation and maintenance of the TuckAway electric monitor, and to assist in attaining the best possible performance from the unit. Read and understand these operating instructions before use.

### TOOLS REQUIRED

- Utility Knife
- Medium Phillips screwdriver
- Small Phillips screwdriver
- Electrician's pliers (multipurpose, stripping and crimping)
- Medium flat screwdriver
- Small flat screwdriver
- 1/2 inch hex head wrench

### PRODUCT RATINGS

Maximum Motor Current Draw:

12 volt versions	14.0 amps each for elevation and rotation motors 3.0 amps for nozzle pattern motor
24 volt versions	7.5 amps each for elevation and rotation motors 1.5 amps for nozzle pattern motor

Normal Operating Current: (Depending on operating conditions—pressure, flow, etc.)

12 volt versions	3.0 to 10.0 amps each for elevation, rotation, and stow motors 0.7 amps for nozzle pattern motor
24 volt versions	2 - 5 amps each for elevation and rotation motors 0.4 amps for nozzle pattern motor

Minimum Voltage: (Truck engine must be operating for proper voltage requirement.)

- All 12 volt motors: 11.5 volts while operating
- All 24 volt motors: 23 volts while operating

Maximum Flow: 1000 gpm (3800 lpm)

Maximum Pressure: 200 psi (14 bar)

### PRODUCT WARNINGS

- ⚠ WARNING: For fire fighting use only by trained fire fighters.
- ⚠ WARNING: Charge the unit slowly. Rapid charging may cause a pressure surge that has the potential to cause an injury, or damage the monitor.
- ⚠ WARNING: DO NOT stow or deploy the TuckAway monitor while flowing. Pressing the stow or deploy buttons causes the nozzle to move automatically and the water stream may cause damage to equipment or injury to personnel could result.
- ⚠ WARNING: Aim the unit in a safe direction before pumping water through it. (i.e. Away from power lines)
- ⚠ WARNING: Although the logic circuit board includes a water-resistant coating, it is important to keep water out of the control and logic boxes. Prolonged exposure to water will cause damage. When the cover of the control or logic box is removed, check that the O-ring under the cover is intact and free of dirt and debris.

- △ WARNING: The TuckAway monitor uses current limiting for both the monitor and nozzle. Use only appropriate Akron Brass Company nozzles.
- △ WARNING: Do not use the electric controls when the override cranks are being used or are in position for use.
- △ WARNING: Replace the identification tags if they should become worn or damaged.
- △ WARNING: DO NOT exceed the maximum pressure or flow ratings of the monitor. Exceeding these ratings may lead to an injury or may cause damage to the monitor.
- △ WARNING: DO NOT install shutoffs on the outlet of the TuckAway electric monitor. Shutoffs increase the potential for pressure surges due to water hammer, which have the potential to cause an injury or damage the monitor.
- △ WARNING: If not equipped with an automatic drain valve, drain the TuckAway monitor after use to prevent "freeze damage".
- △ WARNING: Ensure the thread on the nozzle swivel matches the thread on the monitor outlet. Do not over tighten the nozzle onto the unit.
- △ WARNING: The TuckAway monitor, nozzle, logic box, control box, tether controller, and field adjustable stops are made for optimal performance. Do not alter in any manner.
- △ WARNING: Ensure that the TuckAway is returned to the stow position after use.
- △ WARNING: The TuckAway monitor was designed for use with the Akromatic nozzle. Use of any other nozzle could affect the speed or operation of the unit and should be tested before being put into service.
- △ WARNING: Make the connection of the vehicle and auxiliary battery the final step.

## **MECHANICAL MONITOR ATTACHMENT**

- △ WARNING: INSUFFICIENT STRUCTURAL SUPPORT CAN LEAD TO FAILURE, WHICH HAS POTENTIAL TO CAUSE AN INJURY. THEREFORE, ADDITIONAL STRUCTURAL SUPPORT AT THE INLET FLANGE OR AT THE INLET ELBOW (Figure 1) MAY BE REQUIRED. (Contact Akron Brass Customer Service for assistance.)

## **ROTATIONAL STOPS**

The rotational stops set the boundaries for the area that the monitor is allowed to travel. The monitor is shipped with a stop in location 2 which gives a 90° clockwise and 90° counter-clockwise rotation (See Figure 2). The 45° clockwise and 45° counter-clockwise rotation is achieved by adding stops in location 1 & 3 and a plug in location 2. Both the plugs and the stops have a 1/2" hex head. Refer to Figure 2 to determine which stop location is needed for the desired rotation. Also set DIP Switch 4 ON if ± 45° rotation is desired.

## **VERTICAL STOP**

The vertical stop will limit the elevation of the outlet. The monitor is shipped with a vertical elevation of 30° above horizontal. The monitor can be changed to 90° above horizontal by replacing the stop with the 3/4" hex head plug in the 30° stop location (See Figure 2).

## **MECHANICAL ATTACHMENT OF CONTROLLER AND LOGIC BOX**

### **A. CONTROLLER AND TETHER CONNECTOR ATTACHMENT**

Mounting hole dimensions are given in Figure 3. The controller and tether connector should be installed prior to electrical connection to the logic box.

### **B. LOGIC BOX ATTACHMENT**

The TuckAway logic box must be mounted close enough to the monitor to allow the wiring harness to reach the monitor. The logic box overall dimensions and mounting hole dimensions are given in Figure 4.

# ELECTRICAL INSTALLATION INSTRUCTIONS

## A. CONTROLLER OR TETHER CONNECTOR ELECTRICAL ATTACHMENT

These instructions are for attaching the controller or the tether connector to the logic box. The controller and tether connector are supplied with 8 ft. of cable.

- STEP 1** Determine the length of cable needed to reach the logic box, add 6" and then cut the remainder off.
- STEP 2** Remove the cable grip nut for the appropriate cable from the logic box, **DO NOT REMOVE THE CABLE GRIP**. Thread cable grip nut on the cable with the threads facing out. On the same end of the cable, remove 6 inches of the outer casing of the cable and strip back 3/8" from each of the wires.
- STEP 3** Loosen the 4 logic box cover screws and set the logic box cover aside. Thread the wires through the "control box hole" in the logic box (see Figure 4). Pull enough cable through the cable grip to ensure a good fit. Tighten the cable grip nut and attach the individual wires to the proper terminals (see wiring diagram, Figure 5). Note: The controller and the tether connector can be attached to either terminal: Master (TB2) or Slave (TB3). The one attached to the Master (TB2) terminal will have the overriding capabilities. Adjust the DIP switch settings as needed. (Refer to the description below). Reattach the logic box cover and secure with the 4 screws.

## B. MONITOR AND VEHICLE BATTERY ELECTRICAL ATTACHMENT

These instructions are for attachment of the monitor wiring harness (TB3) and the vehicle battery (TB2).

- ⚠ **WARNING:** The recommended wire size for the vehicle battery power lead (TB2) is 10 AWG wire. If smaller diameter wiring is used, no less than 12 AWG, a minimum 11.5 volts is needed at the power leads (TB2) when under a load (operating).

- STEP 4** Remove the cable grip nut for the appropriate cable from the logic box (see Figure 4), **DO NOT REMOVE THE CABLE GRIP**. Thread the cable grip nut on the correct cable with the threads facing out.
- STEP 5** Loosen the 4 logic box cover screws and set the logic box cover aside. Thread the cable through the correct logic box cable grip (see Figure 4). Pull enough cable through the cable grip to ensure a good fit. Tighten the cable grip nut and attach the individual wires to the proper terminals (see wiring diagram, Figure 5). Reattach the logic box cover and secure with the 4 screws.

## C. SENSOR CALIBRATION PROCEDURE

The following instructions are for the calibration of the potentiometer sensors.

- STEP 1** Install a Stop in the #2 Stop/Plug location for the Rotational Travel (See Figure 2 - Side View). Install a Stop in the Horizontal Stop location (See Figure 2 - Top View). Remove all other stops and plugs from the Elevation and Rotational locations.
- STEP 2** Ensure the Sensors shafts are rotated to the counter-clockwise end stop; and then install. (The shaft will continue to rotate but with some resistance when the sensor is at the end stop.)
- STEP 3** Drive the Rotational Motor all the way to the left end stop and drive the Elevation Motor all the way to the bottom end stop.
- STEP 4** The potentiometer sensors are now calibrated; remove the two Elevation and Rotational stops. Install all the plugs and stops in the desired locations (Figure 2).

## OPERATING INSTRUCTIONS

### A. STARTUP

1. Upon initial installation of a logic box or after maintenance (disassembly/reassembly) of the unit, the mechanical unit may NOT be synchronized with the logic box (i.e. the electronics may point left while the mechanical unit points right).
2. Hold either the LEFT or RIGHT switch ON until the end of travel is reached. Continue holding the switch ON while momentarily turning the DEPLOY switch ON, then releasing the DEPLOY switch. Release the LEFT or RIGHT switch.
3. Then hold the DOWN switch ON until the end of travel is reached. If the unit will not move DOWN, use the UP switch instead, until the end of travel is reached. In either case, continue holding the switch ON at the end of travel while momentarily turning the DEPLOY switch ON, then releasing the DEPLOY switch. Release the DOWN or UP switch.
4. The unit will now be synchronized and will allow full motion in all directions (as set via the DIP switches).

### B. PANEL CONTROLLER OPERATION

The panel controller is used to control the monitor and nozzle.

1. To deploy the monitor for use:  
Lift the safety cover on the STOW/DEPLOY switch and push the toggle switch up and release.
2. To stow the monitor after use:  
Lift the safety cover on the STOW/DEPLOY switch and push the toggle switch down and release.
3. To change the horizontal monitor position toward the right or left:  
Press the proper toggle switch toward "RIGHT" or "LEFT" respectively, as labeled on the controller, until the desired position is reached.
4. To change the vertical monitor nozzle position upward or downward:  
Press the proper toggle switch toward "RAISE" or "LOWER" respectively, as labeled on the controller, until the desired position is reached.
5. To change the nozzle pattern toward the straight stream or fog position:  
Press the proper toggle switch toward "STRAIGHT" or "FOG" respectively, as labeled on the controller, until the desired nozzle position is reached.

### C. EMERGENCY STOP DURING DEPLOY OR STOW

If it is necessary to immediately stop the TuckAway monitor during the deploy or stow sequence, activate any switch on the control panel and the unit will stop moving. To complete the stow or deploy sequence after an emergency stop, activate and release the stow/deploy toggle switch. This will automatically continue the stow/deploy sequence. Be sure to completely stow or deploy the monitor before flowing water.

### D. MANUAL OVERRIDE CONTROLS

The manual override control is to be used only when the power to the monitor is off. A single override crank with a 1/4" hex drive is provided and attached to the monitor for use on both the horizontal and vertical override controls. To use the manual override, insert the hex drive end of the override crank into the hexagon shaped hole on the shaft end opposite the motor. Rotate the override crank in the desired direction to aim the monitor. The crank is not intended for use while flowing water, but rather to stow a non-working monitor for transport to repair facilities.



**WARNING:** When the override crank is no longer in use, put it back in the storage position. Do not use the electric controls when the override crank is being used or is in position for use.

## E. LEARN MODE (DIP Switch 7 and 8 must be ON)

The learn mode allows the operator to teach the monitor a new final position at Stow or Deploy.

To learn a new Deploy position:

Start with the unit in the stowed position. Hold the Deploy switch ON. When it reaches the default deployed position, the monitor will stop, continue to hold the Deploy switch while using the up/down and left/right switches to position the unit at the desired deployed position. Release the Deploy switch last and this will be the new learned position.

NOTE: If you release the Deploy switch and try to activate the Deploy switch again, the monitor will stop (E-Stop) and flash code 3 (See Error codes).

To learn a new Stow position:

Start with the unit somewhere in the deployed state. Hold the Stow switch ON. When it reaches the default stow position, the monitor will stop, continue to hold the Stow switch while using the up/down and left/right switches to position the unit at the desired stowed position. Release the Stow switch last and this will be the new learned position.

NOTE: If you release the Stow switch and try to activate the stow switch again, the monitor will stop

△ (E-Stop) and flash code 3 (See Error codes).

**WARNING:** The nozzle position may need to be reprogrammed in the event of variable loads on the motor. Possible load situations include extreme temperatures, changing nozzles, wear and tear, etc.

## MAINTENANCE INSTRUCTIONS

Your TuckAway monitor and nozzle should be inspected prior to and after each use to ensure it is in good operating condition. Periodically, an unanticipated incident may occur where the unit is misused in a manner that is inconsistent with standard operating practices. A partial list of potential misuses includes:

- Operating above the maximum rated pressure or flow.
- Prolonged exposure to temperatures above 130°F, or below -25°F.
- Operating in a corrosive environment.
- Having the TuckAway nozzle hit a fixed object during operation or transportation.
- Other misuse that might be unique to your specific environment.

Also, there are many “tell tale” signs that indicate repair is in order, such as:

- Controls that are either inoperable or difficult to operate.
- Excessive wear
- Poor discharge performance
- Water leaks.

If any of the above situations are encountered, the TuckAway monitor should be taken out of service, repaired, and tested by a qualified technician before placing back in service.

## A. MOTOR REPLACEMENT

To replace the horizontal, vertical motors:

1. Disconnect power from the unit.
2. Loosen and remove the 4 socket screws from the gearbox housing
3. Slowly remove the motor assembly and gearbox housing from the unit.

**Important: Make sure the internal gear remains in place, (hold with a screwdriver), to avoid gear alignment problems.**

4. Loosen and remove the 4 socket head cap screws from the inside of the gearbox housing that hold the housing and the motor assembly together.
5. Remove the gearbox housing from the motor assembly.
6. Replace both O-ring seals on the gearbox housing.

7. Attach the new motor assembly to the gearbox housing, making sure all 4 screws are tight.
8. Install the motor and gearbox housing assembly to the unit making sure all 4 socket screws are tight. It may be necessary to rotate the motor slightly to get the motor gear to line up with the gears inside the gearbox. Hint: Use the override crank manual.
9. Restore power to the unit.
10. Test the operation of the unit.

Call Akron Brass Technical Service if any problems are encountered.

## B. FAULT CODES

Your TuckAway monitor comes with a built in diagnostic tool. On the control panel is a small LED indicator. The primary function of the LED indicator is to indicate whether the monitor is stowed or deployed. The LED indicator also functions as a Fault Indicator.

**Deployed:** The light will repeatedly flash twice as the unit is deploying. When the fully deployed position is reached the light will stop flashing and remain on.

NOTE: As soon as the deploy sequence begins, the light in the cab will turn on.

**Stowed:** When the fully stowed position is reached the LED indicator will go out.

NOTE: The light in the cab will also go out when fully stowed.

**Fault Code 1:** Fault code 1 is represented when the light flashes continually. If the EEPROM on the circuit board is faulty, Fault 1 will occur.

*Correction:* *The circuit board must be replaced*

**Fault Code 2:** Fault code 2 is normal during the deploy sequence and is represented when the light repeatedly flashes twice. Code 2 is not a fault, but occurs when the deploy button is pressed and automatically ends when the fully deployed position is reached.

Operation of any switch while flashing twice will cause the monitor to go into E-stop mode.

**Fault Code 3:** Fault code 3 is represented when the light repeatedly flashes 3 times. This fault code indicates an emergency stop (E-stop) occurred during stow or deploy. If any switch is pushed during the stow or deploy sequence all movement will stop and Fault 3 will flash.

*Correction:* *Activate the deploy or stow switch. This will continue the sequence until the light stays on constantly at full deployment or turns off at stow. Be sure to completely stow or deploy the monitor before flowing water.*

**Fault Code 4:** Fault Code 4 is represented when the light flashes four times. This indicates the monitor was prevented from completing the Deploy sequence in the vertical direction.

*Correction:* *This can be cancelled out by removing any obstructions and completing the sequence by activating the Stow or Deploy switch.*

**Fault Code 5:** Fault Code 5 is represented when the light flashes five times. This indicates the monitor was prevented from completing the Deploy sequence in the horizontal direction.

*Correction:* *This can be cancelled out by removing any obstructions and completing the sequence by activating the Stow or Deploy switch.*

**Fault Code 6:** Fault Code 6 is represented when the light flashes six times. This indicates the monitor was prevented from completing the Stow sequence in the vertical direction.

*Correction:* *This can be cancelled out by removing any obstructions and completing the sequence by activating the Stow or Deploy switch.*

**Fault Code 7:** Fault Code 7 is represented when the light flashes seven times. This indicates the monitor was prevented from completing the Stow sequence in the horizontal direction.

Figure 1

TOP VIEW - DEPLOYED

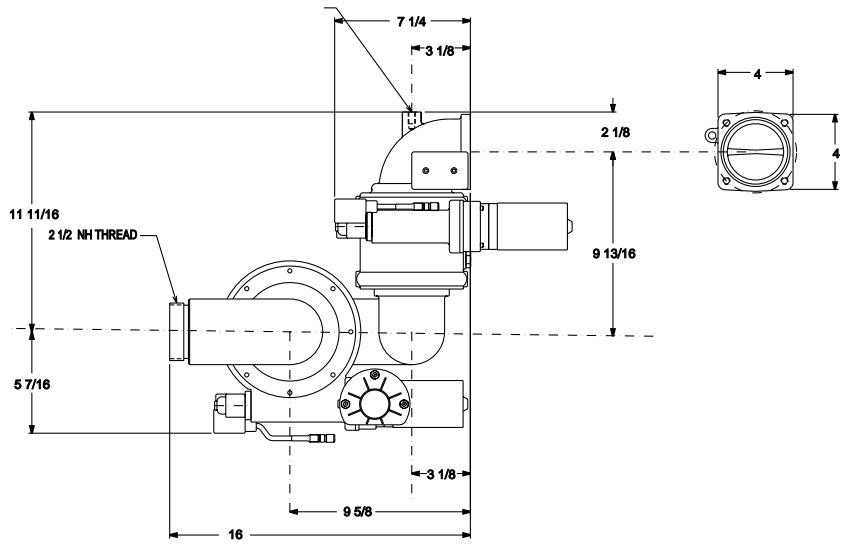

SIDE VIEW - DEPLOYED

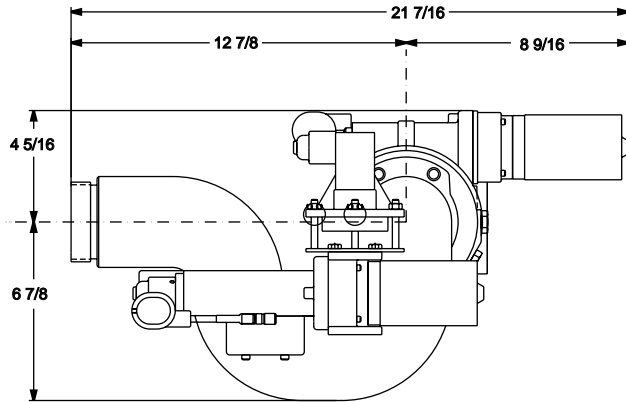

FRONT VIEW - DEPLOYED

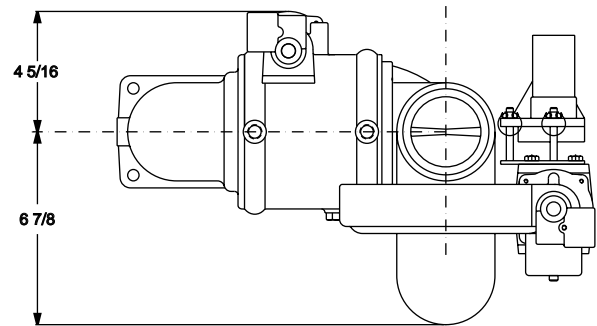

FRONT VIEW - STOWED

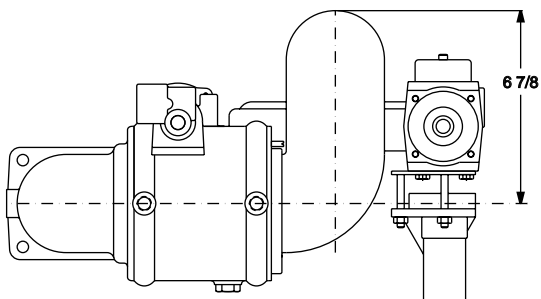

Figure 2

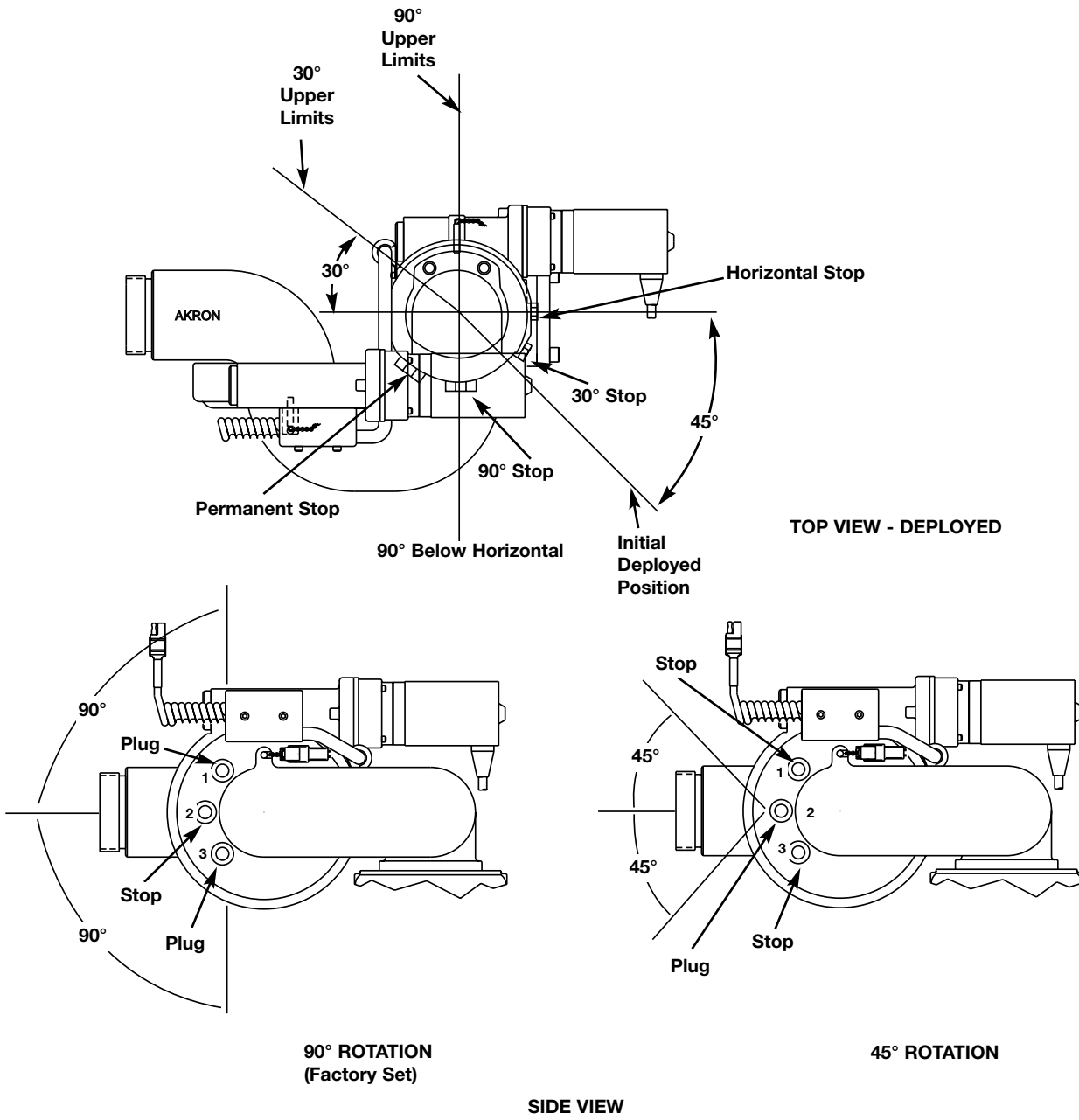
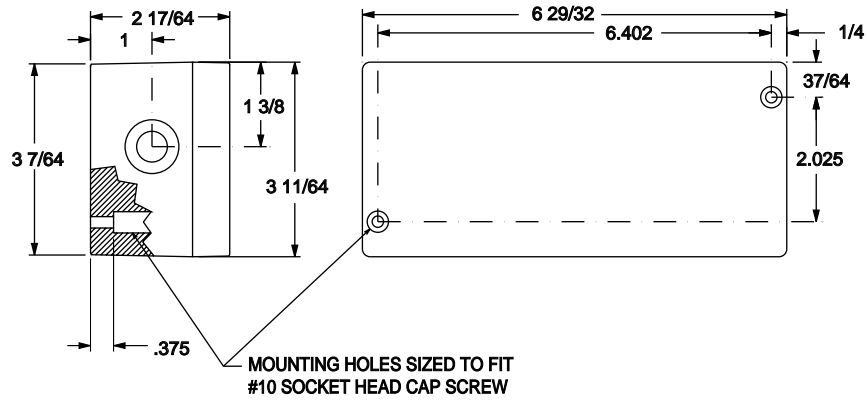
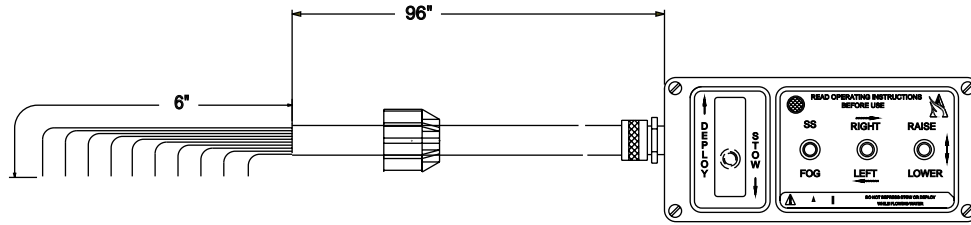

Figure 3

### SURFACE MOUNT CONTROLLER



### TETHER CONNECTOR

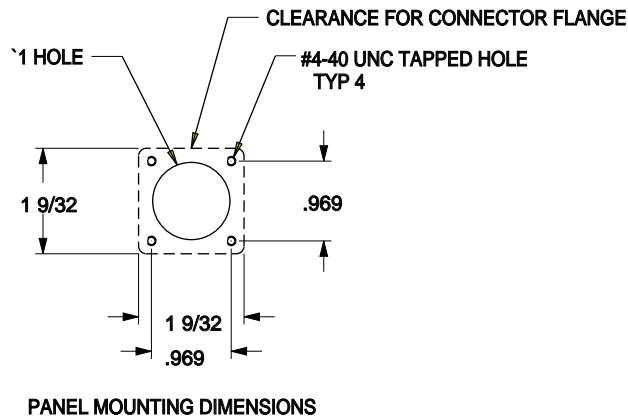
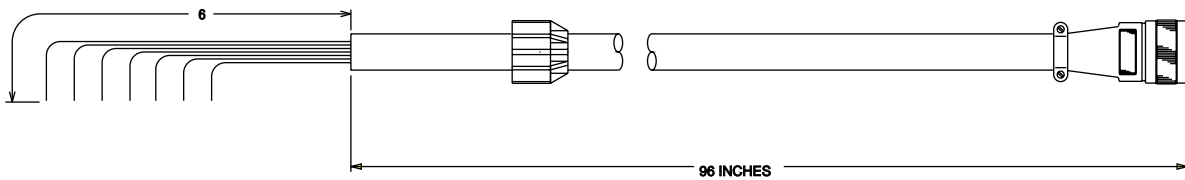

Figure 4

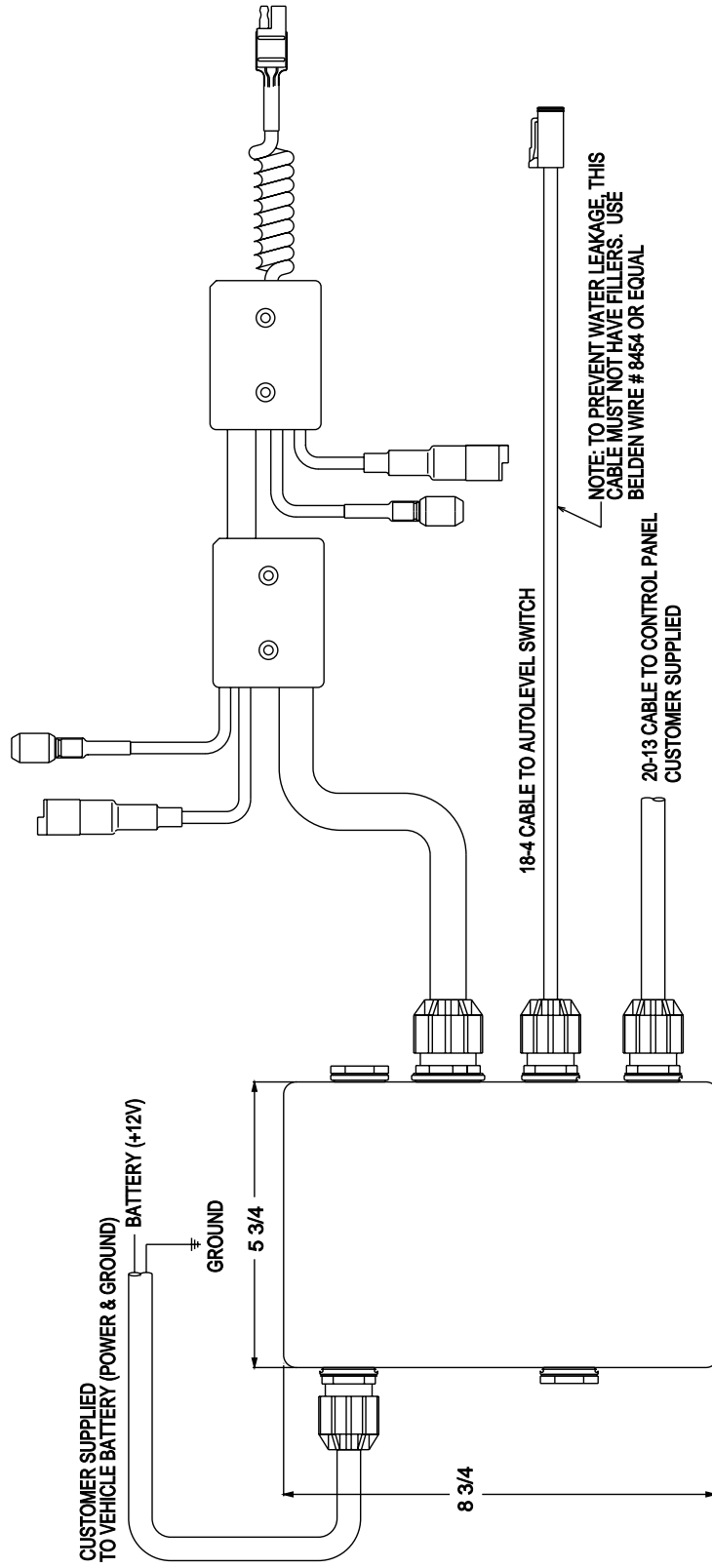
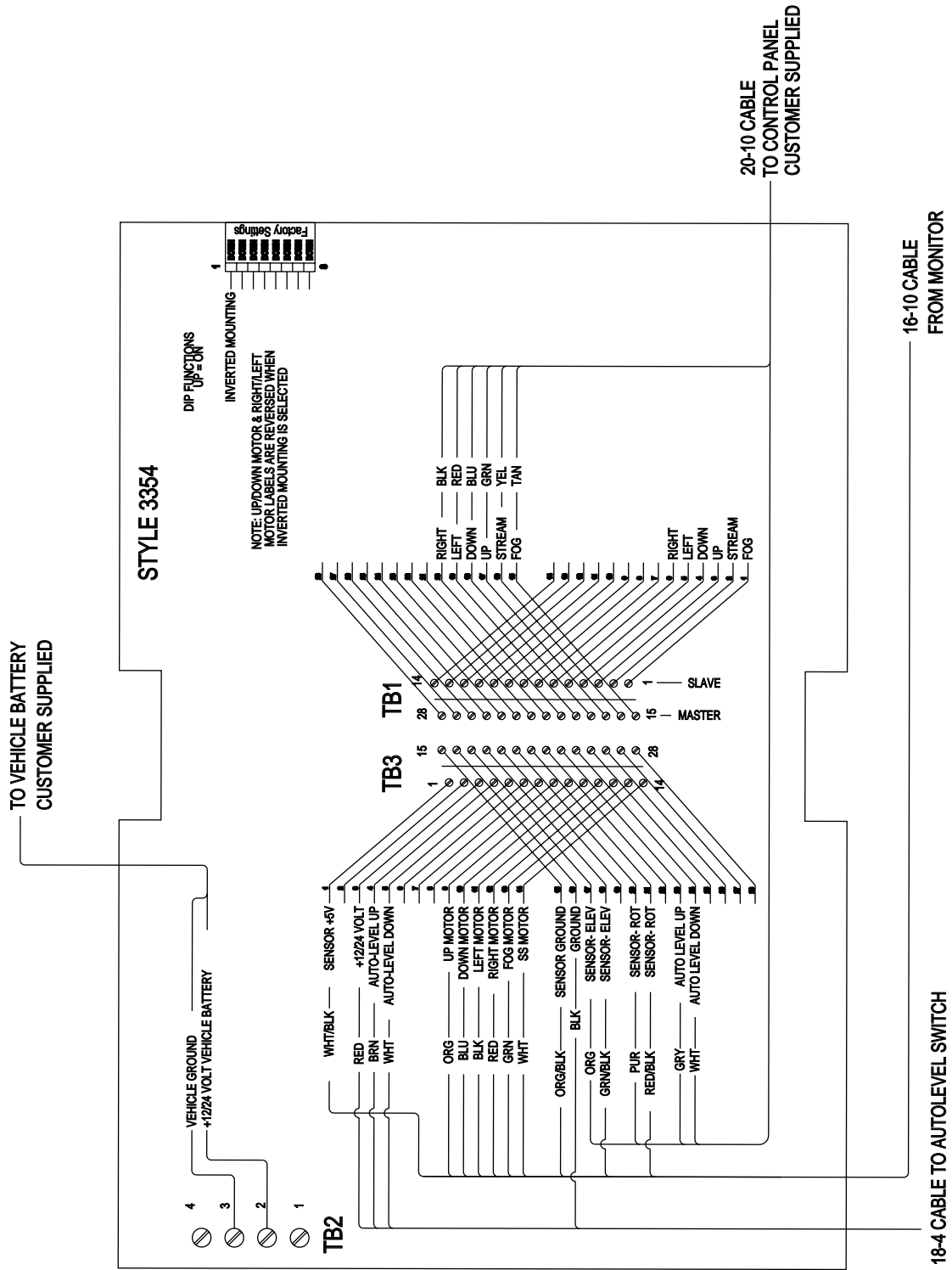

Figure 5





ISO 9001 REGISTERED COMPANY

PHONE: 330.264.5678 or 800.228.1161 | FAX: 330.264.2944 or 800.531.7335 | [www.akronbrass.com](http://www.akronbrass.com)  
Available in Canada through AKRON MANUFACTURING COMPANY  
PHONE: 519.773.8431 | FAX: 519.773.3794

REVISED 02/05

**WARRANTY AND DISCLAIMER:** We warrant Akron Brass products for a period of five (5) years after purchase against defects in materials or workmanship. Akron Brass will repair or replace product which fails to satisfy this warranty. Repair or replacement shall be at the discretion of Akron Brass. Products must be promptly returned to Akron Brass for warranty service.

We will not be responsible for: wear and tear; any improper installation, use, maintenance or storage; negligence of the owner or user; repair or modification after delivery; damage; failure to follow our instructions or recommendations; or anything else beyond our control. WE MAKE NO WARRANTIES, EXPRESS OR IMPLIED, OTHER THAN THOSE INCLUDED IN THIS WARRANTY STATEMENT, AND WE DISCLAIM ANY IMPLIED WARRANTY OF MERCHANTABILITY OR FITNESS FOR ANY PARTICULAR PURPOSE. Further, we will not be responsible for any consequential, incidental or indirect damages (including, but not limited to, any loss of profits) from any cause whatsoever. No person has authority to change this warranty.

© Premier Farnell Corporation. 2000 All rights reserved. No portion of this can be reproduced without the express written consent of Premier Farnell Corporation.

**A Premier Farnell Company**