



STYLE 3352 TUCKAWAY™ ELECTRIC MONITOR INSTALLATION, OPERATING, AND MAINTENANCE INSTRUCTIONS

The following is intended to provide the basic instructions for installation, operation and maintenance of the TuckAway electric monitor, and to assist in attaining the best possible performance from the unit. Read and understand these operating instructions before use.

TOOLS REQUIRED

- Utility Knife
- Medium Phillips screwdriver
- Small Phillips screwdriver
- Electrician's pliers (multipurpose, stripping and crimping)
- Medium flat screwdriver
- Small flat screwdriver
- 1/2 inch hex head wrench

PRODUCT RATINGS

Maximum Motor Current Draw:

12 volt versions	14.0 amps each for elevation and rotation motors 3.0 amps for nozzle pattern motor
24 volt versions	7.5 amps each for elevation and rotation motors 1.5 amps for nozzle pattern motor

Normal Operating Current: (Depending on operating conditions—pressure, flow, etc.)

12 volt versions	3.0 to 10.0 amps each for elevation, rotation, and stow motors 0.7 amps for nozzle pattern motor
24 volt versions	2 - 5 amps each for elevation and rotation motors 0.4 amps for nozzle pattern motor

Minimum Voltage: (Truck engine must be operating for proper voltage requirement.)

- All 12 volt motors: 11.5 volts while operating
- All 24 volt motors: 23 volts while operating

Maximum Flow: 1000 gpm (3800 lpm)

Maximum Pressure: 200 psi (14 bar)

PRODUCT WARNINGS

- ⚠ WARNING: For fire fighting use only by trained fire fighters.
- ⚠ WARNING: Charge the unit slowly. Rapid charging may cause a pressure surge that has the potential to cause an injury, or damage the monitor.
- ⚠ WARNING: Aim the unit in a safe direction before pumping water through it. (i.e. Away from power lines)
- ⚠ WARNING: Although the logic circuit board includes a water-resistant coating, it is important to keep water out of the control and logic boxes. Prolonged exposure to water will cause damage. When the cover of the control or logic box is removed, check that the O-ring under the cover is intact and free of dirt and debris.
- ⚠ WARNING: The TuckAway monitor uses current limiting for both the monitor and nozzle. Use only appropriate Akron Brass Company nozzles.
- ⚠ WARNING: Do not use the electric controls when the override cranks are being used or are in position for use.

- △ WARNING: Replace the identification tags if they should become worn or damaged.
- △ WARNING: DO NOT exceed the maximum pressure or flow ratings of the monitor. Exceeding these ratings may lead to an injury or may cause damage to the monitor.
- △ WARNING: DO NOT install shutoffs on the outlet of the TuckAway electric monitor. Shutoffs increase the potential for pressure surges due to water hammer, which have the potential to cause an injury or damage the monitor.
- △ WARNING: If not equipped with an automatic drain valve, drain the TuckAway monitor after use to prevent “freeze damage”.
- △ WARNING: Ensure the thread on the nozzle swivel matches the thread on the monitor outlet. Do not over tighten the nozzle onto the unit.
- △ WARNING: The TuckAway monitor, nozzle, logic box and field adjustable stops are made for optimal performance. Do not alter in any manner.
- △ WARNING: The TuckAway monitor was designed for use with the Akromatic nozzle. Use of any other nozzle could affect the speed or operation of the unit and should be tested before being put into service.
- △ WARNING: Make the connection of the vehicle battery the final step.

MECHANICAL MONITOR ATTACHMENT

- △ WARNING: INSUFFICIENT STRUCTURAL SUPPORT CAN LEAD TO FAILURE, WHICH HAS POTENTIAL TO CAUSE AN INJURY. THEREFORE, ADDITIONAL STRUCTURAL SUPPORT AT THE INLET FLANGE OR AT THE INLET ELBOW (Figure 1) MAY BE REQUIRED. (Contact Akron Brass Customer Service for assistance.)

The TuckAway monitor is to be mounted on the waterway with eight 5/8” bolts and nuts of grade five minimum and suitable washers with a minimum of six threads engagement. The bolts must be tightened in a criss-cross pattern progressively increasing tightening torque to a maximum of 100 lb.ft.dry.

ELEVATION STOPS

The elevation stops set the boundaries for the area that the monitor is allowed to travel. The monitor is shipped with a stop in location 2 which gives a $\pm 90^\circ$ travel (See Figure 2). The $\pm 45^\circ$ travel is achieved by adding stops in location 1 & 3 and a plug in location 2. Both the plugs and the stops have a 1/2" hex head. Refer to Figure 2 to determine which stop location is needed for the desired rotation.

ROTATIONAL STOP

The rotation stops set the boundaries for the area that the monitor is allowed to travel. The monitor is shipped with stops in location 2 & 3 which gives a $\pm 90^\circ$ travel (See Figure 2). The $\pm 45^\circ$ travel is achieved by adding stops in location 1 & 4. Both the plugs and the stops have a 1/2" hex head. Refer to Figure 2 to determine which stop location is needed for the desired rotation.

MECHANICAL ATTACHMENT OF THE LOGIC BOX

The TuckAway logic box must be mounted close enough to the monitor to allow the wiring harness to reach the monitor. The logic box overall dimensions and mounting hole dimensions are given in Figure 3.

ELECTRICAL INSTALLATION INSTRUCTIONS

A. CONTROLLER ELECTRICAL ATTACHMENT

These instructions are for attaching the controller or the tether connector to the logic box. The controller are supplied with 8 ft. of cable.

- STEP 1** Determine the length of cable needed to reach the logic box, add 6” and then cut the remainder off.
- STEP 2** Remove the cable grip nut for the appropriate cable from the logic box, DO NOT REMOVE THE CABLE GRIP. Thread cable grip nut on the cable with the threads facing out. On the

same end of the cable, remove 6 inches of the outer casing of the cable and strip back 3/8" from each of the wires.

- STEP 3** Loosen the 6 logic box cover screws and set the logic box cover aside. Thread the wires through the "control box hole" in the logic box (see Figure 3). Pull enough cable through the cable grip to ensure a good fit. Tighten the cable grip nut and attach the individual wires to the proper terminals (see wiring diagram, Figure 4). Note: The controller can be attached to either terminal: Master or Slave. The one attached to the Master terminal will have the overriding capabilities. Reattach the logic box cover and secure with the 6 screws.

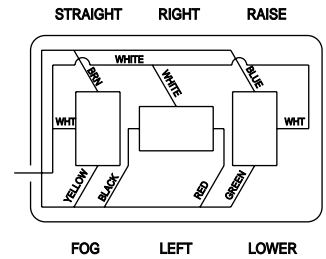

B. MONITOR AND VEHICLE BATTERY ELECTRICAL ATTACHMENT

These instructions are for attachment of the monitor wiring harness (TB3) and the vehicle battery (TB2).

- ⚠ WARNING:** The recommended wire size for the vehicle battery power lead (TB2) is 10 AWG wire. If smaller diameter wiring is used, no less than 12 AWG, a minimum 11.5 volts is needed at the power leads (TB2) when under a load (operating).

- STEP 4** Remove the cable grip nut for the appropriate cable from the logic box (see Figure 3), DO NOT REMOVE THE CABLE GRIP. Thread the cable grip nut on the correct cable with the threads facing out.
- STEP 5** Loosen the 6 logic box cover screws and set the logic box cover aside. Thread the cable through the correct logic box cable grip (see Figure 3). Pull enough cable through the cable grip to ensure a good fit. Tighten the cable grip nut and attach the individual wires to the proper terminals (see wiring diagram, Figure 4). Reattach the logic box cover and secure with the 4 screws.

OPERATING INSTRUCTIONS

A. PANEL CONTROLLER OPERATION

The panel controller is used to control the monitor and nozzle.

- To change the horizontal monitor position toward the right or left:
Press the proper toggle switch toward "RIGHT" or "LEFT" respectively, as labeled on the controller, until the desired position is reached.
- To change the vertical monitor nozzle position upward or downward:
Press the proper toggle switch toward "RAISE" or "LOWER" respectively, as labeled on the controller, until the desired position is reached.
- To change the nozzle pattern toward the straight stream or fog position:
Press the proper toggle switch toward "STRAIGHT" or "FOG" respectively, as labeled on the controller, until the desired nozzle position is reached.

B. MANUAL OVERRIDE CONTROLS

The manual override control is to be used only when the power to the monitor is off. A single override crank with a 1/4" hex drive is provided and attached to the monitor for use on both the horizontal and vertical override controls. To use the manual override, insert the hex drive end of the override crank into the hexagon shaped hole on the shaft end opposite the motor. Rotate the override crank in the desired direction to aim the monitor. The crank is not intended for use while flowing water, but rather to stow a non-working monitor for transport to repair facilities.

- ⚠ WARNING:** When the override crank is no longer in use, put it back in the storage position. Do not use the electric controls when the override crank is being used or is in position for use.

MAINTENANCE INSTRUCTIONS

Your TuckAway monitor and nozzle should be inspected prior to and after each use to ensure it is in good operating condition. Periodically, an unanticipated incident may occur where the unit is misused in a manner that is inconsistent with standard operating practices. A partial list of potential misuses includes:

- Operating above the maximum rated pressure or flow.
- Prolonged exposure to temperatures above 130°F, or below -25°F.
- Operating in a corrosive environment.
- Having the TuckAway nozzle hit a fixed object during operation or transportation.
- Other misuse that might be unique to your specific environment.

Also, there are many “tell tale” signs that indicate repair is in order, such as:

- Controls that are either inoperable or difficult to operate.
- Excessive wear
- Poor discharge performance
- Water leaks.

If any of the above situations are encountered, the TuckAway monitor should be taken out of service, repaired, and tested by a qualified technician before placing back in service.

A. MOTOR REPLACEMENT

To replace the horizontal, vertical motors:

1. Disconnect power from the unit.
2. Loosen and remove the 4 socket screws from the gearbox housing
3. Slowly remove the motor assembly and gearbox housing from the unit.
Important: Make sure the internal gear remains in place, (hold with a screwdriver), to avoid gear alignment problems.
4. Loosen and remove the 4 socket head cap screws from the inside of the gearbox housing that hold the housing and the motor assembly together.
5. Remove the gearbox housing from the motor assembly.
6. Replace both O-ring seals on the gearbox housing.
7. Attach the new motor assembly to the gearbox housing, making sure all 4 screws are tight.
8. Install the motor and gearbox housing assembly to the unit making sure all 4 socket screws are tight. It may be necessary to rotate the motor slightly to get the motor gear to line up with the gears inside the gearbox. Hint: Use the override crank manual.
9. Restore power to the unit.
10. Test the operation of the unit.

Call Akron Brass Technical Service if any problems are encountered.

Figure 1

FRONT VIEW

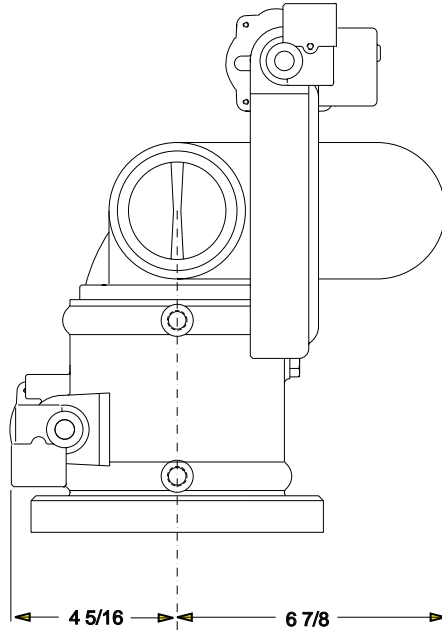

TOP VIEW

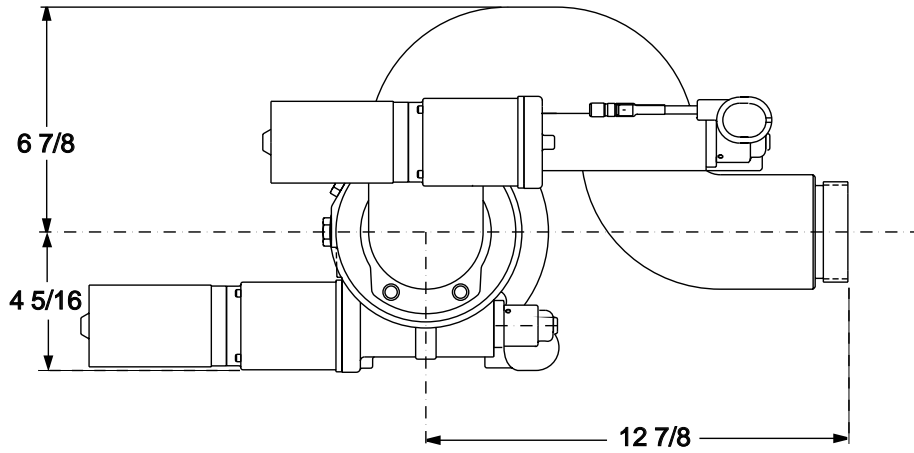

SIDE VIEW

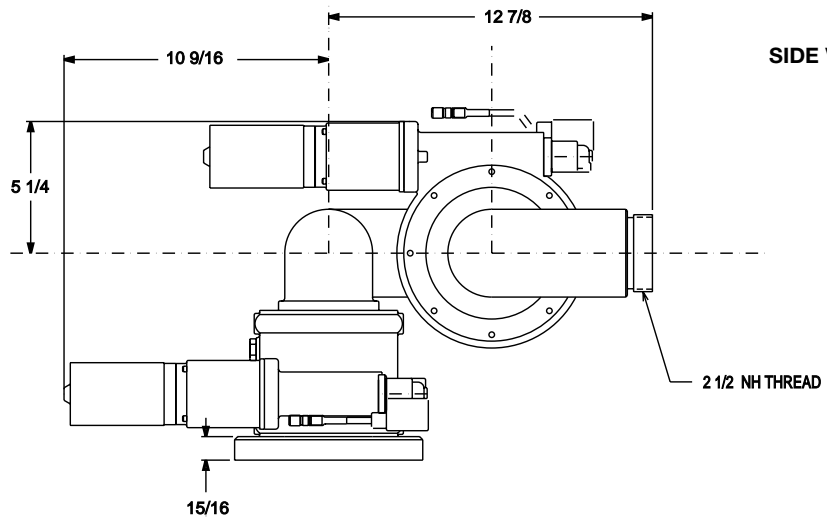
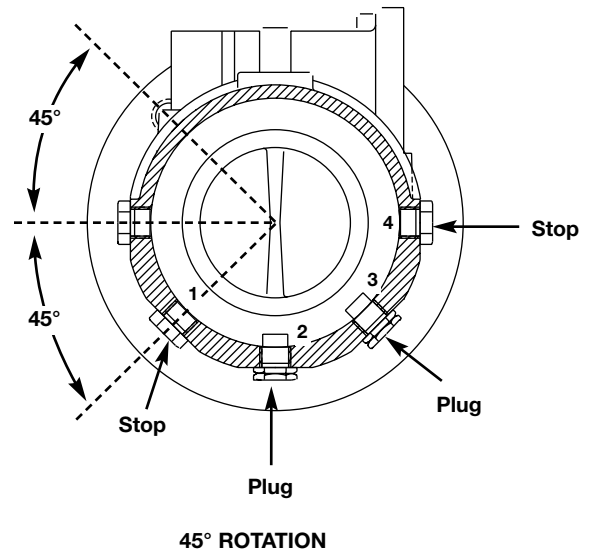
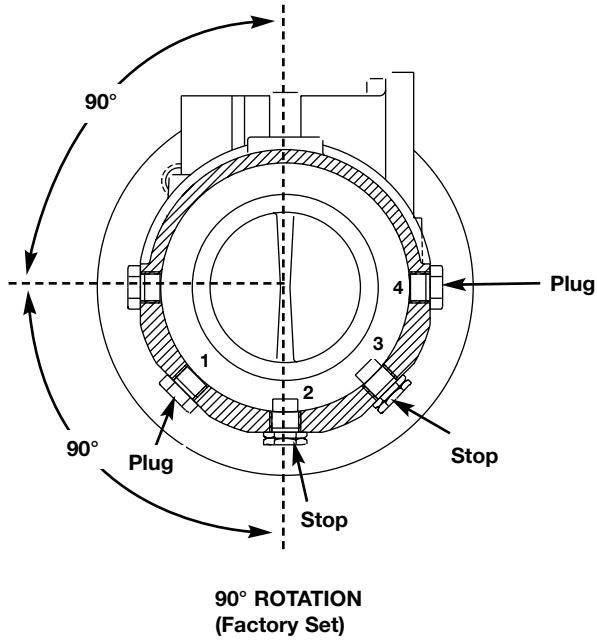
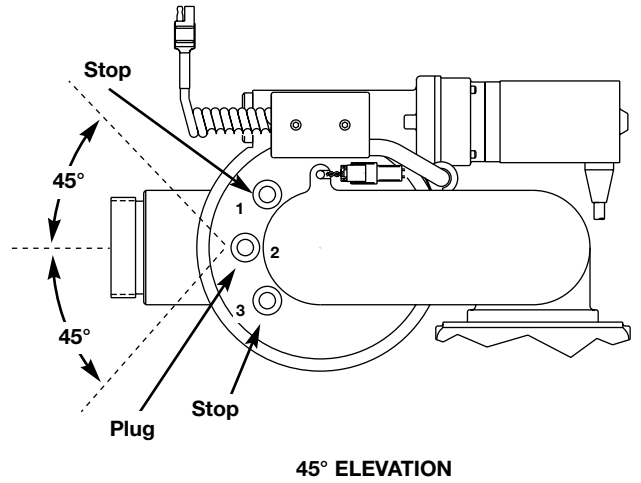
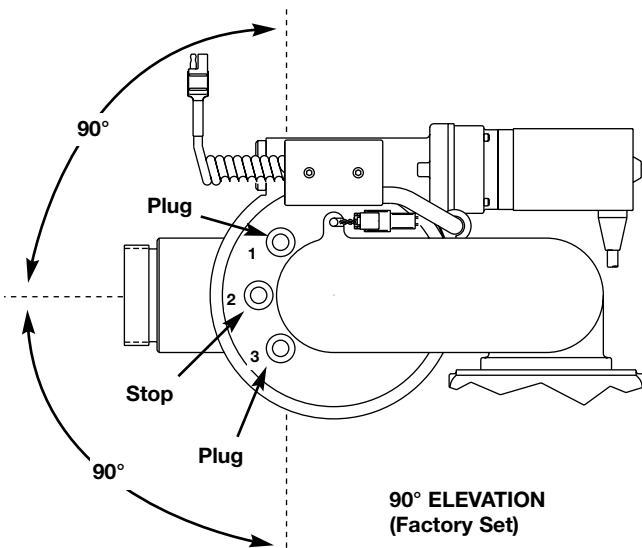

Figure 2



TOP VIEW - DEPLOYED



SIDE VIEW

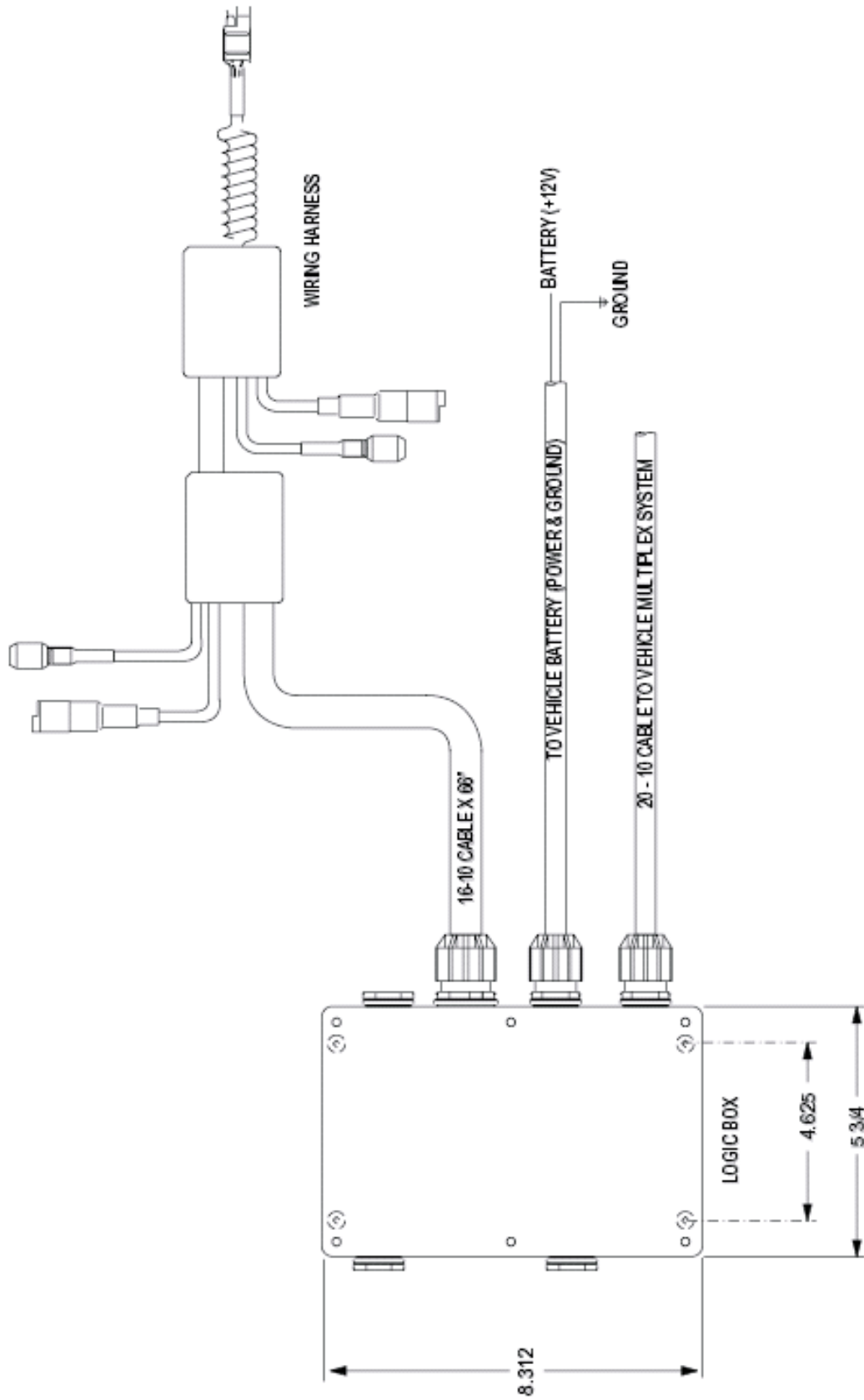
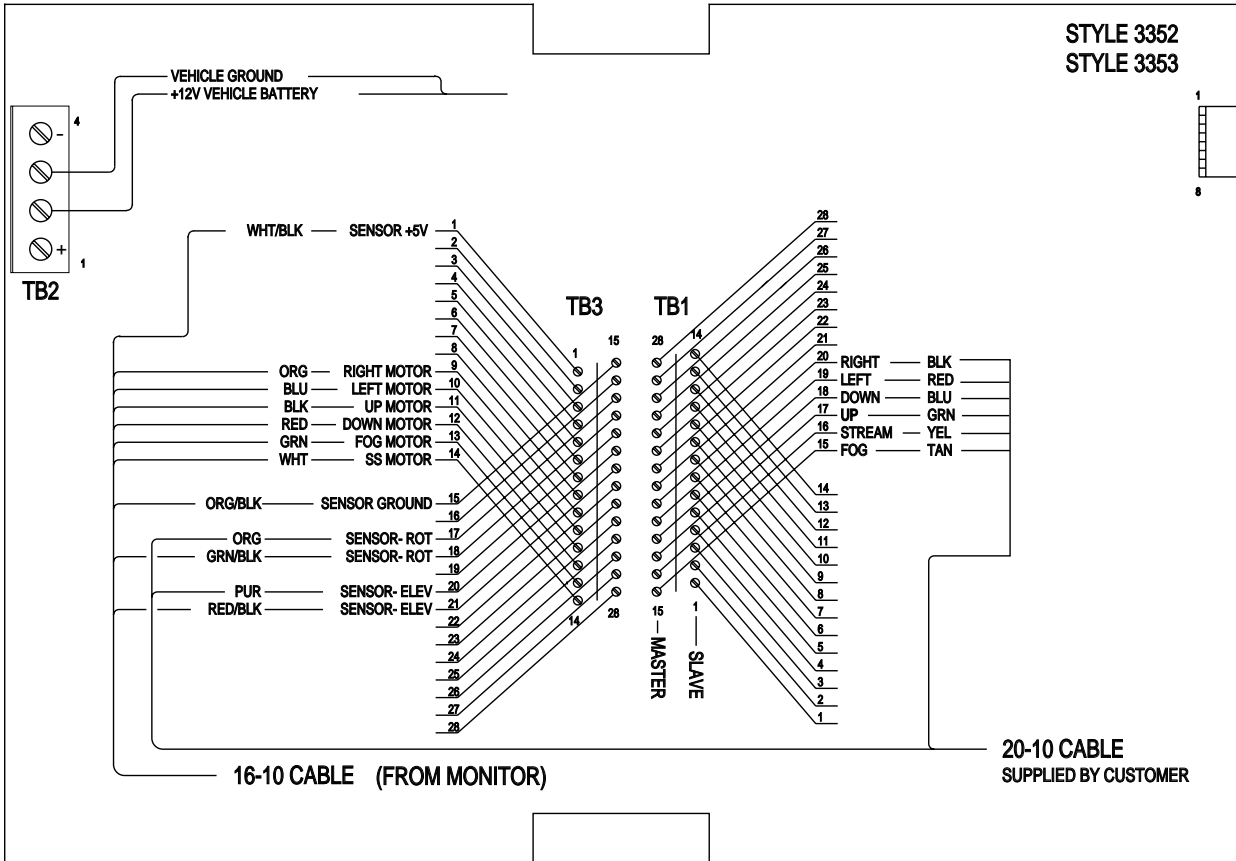

Figure 4



WIRE CONNECTION INSIDE LOGIC BOX



ISO 9001 REGISTERED COMPANY

PHONE: 330.264.5678 or 800.228.1161 | FAX: 330.264.2944 or 800.531.7335 | www.akronbrass.com
Available in Canada through AKRON MANUFACTURING COMPANY
PHONE: 519.773.8431 | FAX: 519.773.3794

REVISED 08/02

WARRANTY AND DISCLAIMER: We warrant Akron Brass products for a period of five (5) years after purchase against defects in materials or workmanship. Akron Brass will repair or replace product which fails to satisfy this warranty. Repair or replacement shall be at the discretion of Akron Brass. Products must be promptly returned to Akron Brass for warranty service. We will not be responsible for: wear and tear; any improper installation, use, maintenance or storage; negligence of the owner or user; repair or modification after delivery; damage; failure to follow our instructions or recommendations; or anything else beyond our control. WE MAKE NO WARRANTIES, EXPRESS OR IMPLIED, OTHER THAN THOSE INCLUDED IN THIS WARRANTY STATEMENT, AND WE DISCLAIM ANY IMPLIED WARRANTY OF MERCHANTABILITY OR FITNESS FOR ANY PARTICULAR PURPOSE. Further, we will not be responsible for any consequential, incidental or indirect damages (including, but not limited to, any loss of profits) from any cause whatsoever. No person has authority to change this warranty.

© Premier Farnell Corporation, 2000 All rights reserved. No portion of this can be reproduced without the express written consent of Premier Farnell Corporation.

A Premier Farnell Company