



STYLE 3030 AKRON® JET RATIO CONTROLLER (JRC) OPERATING INSTRUCTIONS

PRODUCT WARNINGS

- ⚠ WARNING: Since various foam concentrates have different viscosities, they all will not proportion accordingly. It may be necessary to dial up to achieve proper proportioning levels. In no case would you dial down.
- ⚠ WARNING: Ensure the threads on the JRC match the threads on the hose connection.

PRODUCT CAUTIONS

- ⚠ CAUTION: If any tags of bands on the JRC are worn or damaged and cannot be easily read, they should be replaced.
- ⚠ CAUTION: For use with fresh water or standard firefighting foams only. Not recommended for use with salt water. After use with foam or water, flush with fresh water.
- ⚠ CAUTION: For firefighting use only.
- ⚠ CAUTION: The JRC is configured for optimum performance. Do not alter in any manner.
- ⚠ CAUTION: Care should be taken to protect the quick connect coupling. Failure to do so may cause leaking resulting in a failure of the JRC to pick up foam concentrate.
- ⚠ CAUTION: Your JRC should be inspected prior to and after each use to ensure it is in good operating condition. Periodically an unanticipated incident may occur where the JRC is used in a manner inconsistent with standard operating practices. A partial list of potential misuses follows:
 - Operating above maximum rated pressure and flow.
 - Not draining and allowing water to freeze inside the JRC.
 - Dropping the JRC from a height where damage is incurred.
 - Prolonged exposure to temperatures above +130 degrees F or below – 25 degrees F.
 - Operating in a corrosive environment.
 - Other misuse that might be unique to your specific fire fighting environment.

There are many "tell tale" signs that indicate JRC repair is in order, such as:

- Controls are inoperable or difficult to operate.
- Excessive wear.
- Water leaks.

If any of the above situations are encountered, the JRC should be taken out of service and repaired, plus tested by a qualified technician prior to placing back in service.

GENERAL GUIDELINES:

The Akron JRC is designed for use with most types of foam concentrates.

Standard Inlet Operating pressure is 200 psi.

The recommended nozzle to use with the JRC is either the Akron Style 4470 or 4475 AkroFoam™ nozzle.

To use the JRC with an AkroFoam nozzle attach the AkroFoam/Hose Adapter to your 1 1/2" male hose thread. Then attach the quick cam connection to the foam port of the AkroFoam nozzle.

The Akron JRC will deliver a 3% solution 400' through 1 3/4" hose to the AkroFoam self-educing nozzle. The unique design of the JRC body provides approximately 30 gallons of water mixed with up to 30 gallons of foam concentrate to produce the 60 gallons of solution delivered to the AkroFoam nozzle.

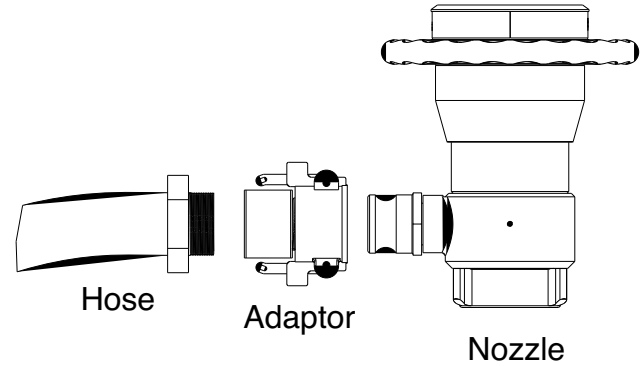

OPERATING INSTRUCTIONS

1. The JRC metering dial must be set to the desired percentage and at the desired flow which must match the nozzle setting.
2. Set the JRC inlet pressure to 200 psi. With the metering dial on the JRC pickup assembly set at 3% @ 1000 gpm and with 200 psi inlet pressure the unit will pickup 30 gallons of foam concentrate (3% of 1000 = 30). The concentrate will mix with 30 gallons of water and be delivered as a 60 gpm solution to an AkroFoam nozzle set on 1000 gpm. The result will be a 3% foam application.
3. Any shutoffs before the nozzle must be fully open. Any attempt to throttle the shutoff will cause the JRC to shut down.
4. After use, the JRC and nozzle must be flushed with clean water for up to 3 minutes to assure all parts are clear of foam. The metering dial should be rotated while flushing.
5. Can be utilized as a dewatering device-removing 30 GPM with 100 psi inlet pressure.

TROUBLESHOOTING

There are several factors which may influence the operation of the JRC. The following is designed to help the user determine which element of the system is at fault when the system is not functioning properly.

1. Inlet pressure: The JRC is designed to operate at 200 psi (1400 kPa/14 bar) at the inlet of the JRC. The JRC will pick up foam at pressures lower than 200 psi but the meter is calibrated for this pressure. If the unit is operated at lower pressures the mix will have a higher percentage of foam than shown on the metering dial. In addition, the nozzle is designed to operate at 100 psi (700 kPa/7bar) nozzle pressure.
2. Pick-up hose suction: All hose lay based on maximum of 10' elevation, measured from the discharge side of the eductor with 200 psi inlet pressure.

MAXIMUM HOSE LAY

The Akron JRC is designed to be used with up to a maximum of 400 feet of 1 3/4" hose. This distance assumes quality hose in good repair and without kinks. In addition, this maximum hose lay does not account for over 10 feet of elevation between the JRC and the nozzle. If after initial set up, the unit does not perform, it's recommended the hose lay distance be reduced.

Contact Akron Brass Customer Service for additional information



PHONE: 330.264.5678 or 800.228.1161 | FAX: 330.264.2944 or 800.531.7335 | www.akronbrass.com
Available in Canada through AKRON MANUFACTURING COMPANY
PHONE: 519.773.8431 | FAX: 519.773.3794

REVISED 09/05

WARRANTY AND DISCLAIMER: We warrant Akron Brass products for a period of five (5) years after purchase against defects in materials or workmanship. Akron Brass will repair or replace product which fails to satisfy this warranty. Repair or replacement shall be at the discretion of Akron Brass. Products must be promptly returned to Akron Brass for warranty service. We will not be responsible for: wear and tear; any improper installation, use, maintenance or storage; negligence of the owner or user; repair or modification after delivery; damage; failure to follow our instructions or recommendations; or anything else beyond our control. WE MAKE NO WARRANTIES, EXPRESS OR IMPLIED, OTHER THAN THOSE INCLUDED IN THIS WARRANTY STATEMENT, AND WE DISCLAIM ANY IMPLIED WARRANTY OF MERCHANTABILITY OR FITNESS FOR ANY PARTICULAR PURPOSE. Further, we will not be responsible for any consequential, incidental or indirect damages (including, but not limited to, any loss of profits) from any cause whatsoever. No person has authority to change this warranty.

© Premier Farnell Corporation, 2000 All rights reserved. No portion of this can be reproduced without the express written consent of Premier Farnell Corporation.

A Premier Farnell Company