



## STYLE 1494 ELECTRIC LADDER PIPE INSTALLATION, OPERATING AND MAINTENANCE INSTRUCTIONS (CE Versions Available)

The following is intended to provide the basic instructions for installation, operating and maintenance of the Electric Ladder Pipe.

### TOOLS REQUIRED

- Utility knife
- Medium Phillips screwdriver
- Small Phillips screwdriver
- Electrician's pliers (multipurpose, stripping and crimping)
- Medium flat screwdriver
- Small flat screwdriver
- ½ inch hex head wrench
- ⅝ Allen Wrench

### PRODUCT RATINGS

Maximum motor current draw:

12 volt versions	14.0 amps for elevation motor 3.0 amps for nozzle pattern motor
24 volt versions	7.5 amps for elevation motor 1.5 amps for nozzle pattern motor

Normal operating current (depending on operating conditions—pressure, flow, etc.):

12 volt versions	3 - 10 amps for elevation motor 0.7 amps for nozzle pattern motor
24 volt versions	2 - 5 amps for elevation motor 0.4 amps for nozzle pattern motor

Minimum Voltage:

- All 12 volt motors: 11.5 volts
- All 24 volt motors: 23 volts
- Mass: 30 lbs. (13.6 kg)

Maximum Flow: 1000 GPM

Maximum Pressure: 200 PSI

Noise Emission: 93 Db @ 1m with maximum flow

### PRODUCT WARNINGS

- ⚠ WARNING: Aim the Electric Ladder Pipe in a safe direction before pumping water through it.
- ⚠ WARNING: Ensure the ladder being used has adequate structural strength to support the reaction force generated during operation.
- ⚠ WARNING: Although the logic box includes a water resistant coating it is important to keep water out of the controllers and logic box. Prolonged exposure to water will cause damage.

When the cover of the controllers or logic box is removed, check that the O-Ring under the cover is intact and free of dirt and debris.

- △ WARNING: The Electric Ladder Pipe uses current limiting for both the monitor and nozzle stops. Use only appropriate Akron Brass® nozzles.
- △ WARNING: Do not use the electric controls when the override crank is being used or is in position for use.
- △ WARNING: Make the connection of the vehicle and auxiliary battery the final step.
- △ WARNING: If any tags or bands are worn or damaged and cannot be easily read, they should be replaced.
- △ WARNING: Disconnect power and disable flow before maintenance.
- △ WARNING: Keep all personnel out of the Danger Zone (in front of the outlet of the monitor - See Dimensional Specifications Figure 1) when the water source is attached. Dangerous flow velocities can cause serious injury.
- △ WARNING: The Electric Ladder Pipe monitor contains moving parts. Keep hands, fingers and objects away from pinch points (Figure 1).
- △ WARNING: Not designed for explosive environments.



## GENERAL INSTRUCTIONS

- Review the instructions, Wiring Schematic (Figure 2), Electrical Component Layout (Figure 3) before installing this unit. This unit operates on 12 volt DC or 24 volt DC depending on the unit chosen. All electrical current flows through the wires, the monitor does not act as a ground. The wires from the control boxes can be cut to the length of the application plus 10 inches (see STEP 2). Do not extend the wires from the logic box to the monitor.
- The auxiliary battery is used to operate the Electric Ladder Pipe. Do not extend the auxiliary battery wires. This will ensure that the proper voltage and current are maintained at the monitor for it to operate properly. The auxiliary battery is automatically recharged by the truck electrical system through the positive terminal (auxiliary battery) and ground terminal on the circuit board (TB2) of the logic box (Figure 2). The vehicle battery terminal in the logic box must have power (turned on) whenever the truck is running so that the auxiliary battery can be recharged properly. If possible, connect the positive wire (vehicle battery) from the logic box directly to the main vehicle battery or main master switch. A diode in the logic box will prevent the auxiliary battery from feeding current back into the main truck electrical system.

**NOTE:** This monitor is not designed for continuous use. A minimum of 11.5 volts must be held at the auxiliary battery to operate the monitor properly. If continuous use of the elevation motor exceeds 1 hour, the auxiliary battery may drop under the minimum voltage requirement. Therefore, it is imperative that the vehicle battery terminal in the logic box be wired hot.

- Not recommended for use in salt water applications.
- For firefighting by trained firefighters only.
- For use with water or standard fire fighting foams only. After use with foam, flush with fresh water.
- Do not use the Electric Ladder Pipe nozzle as a forcible entry tool.
- Drain the Electric Ladder Pipe monitor and nozzle after use to prevent “freeze damage”.
- Ensure that the thread in the nozzle swivel matches the thread on the Ladder Pipe outlet. Do not overtighten the nozzle onto the Ladder Pipe.
- The Electric Ladder Pipe monitor, nozzle, logic box, control boxes, auxiliary battery, are made for optimal performance. Do not alter in any manner.
- Do not install shutoffs on the outlet of the Ladder Pipe.
- Mount the logic box, control boxes and auxiliary battery out of Danger Zone (Figure 3).

# ELECTRICAL INSTALLATION INSTRUCTIONS

## A. CONTROL BOX WIRING AND ATTACHMENT

The Electric Ladder Pipe optional upper and lower controls use the same control box. The following steps will prepare either one or both control boxes for attachment to the logic box.

**STEP 1** If the control box includes an attached cable skip to STEP 6.

**STEP 2** Determine the length of #20-7 cable needed, add 10 inches, then cut. For example, if a five foot length of cable is needed, add 10 inches and cut the cable 5 foot 10 inches long.

**STEP 3** Remove the cable grip nut and washer from the control box and put it on the cable with the threads facing the box. On the same end of the cable remove 4 inches of the outer casing of the cable and strip back 3/8 inch from each of the 7 wires.

**STEP 4** Take the 7 ring terminals from the plastic bag and crimp them on the 7 wires. Remove the four control box cover screws and set the control box cover aside. Thread the 7 wires through the cable grip attached to the control box and attach them to the proper terminals. Tighten the cable grip nut and washer on the cable to the cable grip on the control box to secure the cable. Reattach control box cover and secure with the four screws.

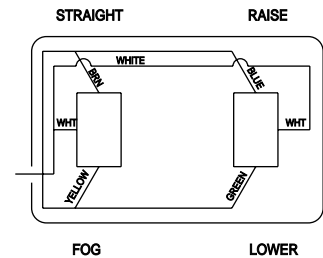

**STEP 5** Remove the cable grip nut from the plastic bag and put it on the other end of the cable with the threads facing out. Remove 6 inches of the outer cover and strip back 3/8 inch from each of the 7 wires.

**STEP 6** Remove the 6 logic box cover screws and set the logic box cover aside. Thread the 7 wires through the upper or lower control hole in the logic box (see component layout, Figure 5). Thread the cable grip washer and cable grip nut with the threads facing the box on the cable. Pull enough cable through the cable grip to ensure a good fit. Tighten the cable grip nut and attach the individual wires to the proper terminals (see wiring diagram Figure 6). Reattach the logic box cover and secure with the 6 screws.

**NOTE:** The lower control and upper control wires must be attached to the correct terminals for the lower control to override the upper control. The one attached to the Master terminal will have the overriding capabilities.

## B. LOGIC BOX / MONITOR WIRING HARNESS ATTACHMENT

These instructions are to attach the logic box / monitor wiring harness to the logic box.

**STEP 7** Disconnect the logic box wiring harness from the monitor wiring harness (Figure 3). Remove the cable grip nut from the logic box and put it on the wiring harness (#16-4) cable with the threads facing out. Thread the wires through the appropriate cable grip hole on the logic box (Figure 3). Pull enough cable through the cable grip to ensure a good fit. Tighten the cable grip nut and attach the individual wires to the proper terminals (Figure 2).

**NOTE:** Do not extend the wiring harness. To ensure proper voltage, attach the supplied wiring harness directly to logic box.

## C. AUXILIARY BATTERY ATTACHMENT

The battery connections should be the last connection made.

**STEP 8** AUXILIARY BATTERY – Remove the cable grip nut from the logic box and place it on the battery (#16-3) cable with the threads facing out. Thread the wires through the appropriate cable grip hole on the logic box (Figure 3). Pull enough cable through the cable grip to ensure a good fit. Tighten the cable grip nut and attach the individual wires to the proper terminals (Figure 2).

#### D. CABLE REEL ATTACHMENT

These instructions are to attach the cable reel in between the logic box and the lower control box along with the power source (Figure 3).

**IMPORTANT CABLE REEL NOTE:** YOU MUST SUPPLY ADEQUATE WIRE SIZE FOR THE POWER SOURCE TO OPERATE THE MONITOR PROPERLY (equivalent to 12 awg). YOU MUST USE 20 AWG OR LARGER FOR THE CONTROLLER WIRES. AKRON BRASS SUPPLIED CABLE REEL HAS 100 FOOT OF USABLE CABLE. DO NOT EXTEND LADDER FURTHER THAN THE USABLE CABLE LENGTH.

**STEP 9** Mount the cable reel in the desired position. Mount the guides at the beginning of each section of the ladder. Place the cable through the guides and up to the logic box. Secure the cable to the top portion of the ladder with cable clamps. Remove ball stop and place in appropriate position.

**NOTE:** Cable may not have same color of wires as shown on Figure 2. Label wire color to function for future reference.

**STEP 10** Remove the cable grip nut from the logic box and place it on the cable reel cable with the threads facing out. Thread the wires through the appropriate cable grip hole on the logic box. Pull enough cable through the grip to ensure a good fit. Tighten the cable grip nut and attach the controller wires to the proper terminals (Figure 2).

**STEP 11** Use the rest of the wires for the power source. You will need to use more than one wire for the positive and negative connections if the wire size is smaller than 12 AWG. Make the appropriate connections to the vehicle battery terminal and the ground terminal in the logic box. Reattach the logic box cover and secure with the 6 screws.

**STEP 12** Open the junction box on the cable reel. Attach the lower control box wires to the proper color-coded wires. Attach the power leads in the junction box to the vehicle battery. Close the junction box and test all functions before using.

**NOTE:** Wire color at junction box may not correspond to wire color at logic box. Use caution and verify corresponding color of wires.

#### E. MECHANICAL MONITOR ATTACHMENT

This unit is equipped with a quick acting clamp which is adjustable to fit the rung spacing of most aerial ladders. It is pre-set at the plant to fit a rung spacing of 15¼" and it may be necessary to adjust the spacing to your ladder.

**NOTE:** Round rung ladders require different clamps than square rung ladders. Do not use if clamps do not match rung shape. Contact Akron Brass for clarification.

To install the pipe on your aerial, follow the simple steps outlined below (Figure 4).

1. Hook upper clamp (1) over top rung and drop the pipe into position.
2. To unlock the handle, compress the safety catch (2) completely with palm of your hand.
3. Raise locking handle (3) completely.
4. Place lower clamp (4) under the second rung and lower the locking handle into the fully locked position.
5. If your rung spacing is other than 15¼", you will need to adjust the position of the lower bracket.
6. Loosen the five screws both front (5) and rear (6).
7. With the handle in the locked position, slide the entire lower bracket until the second rung fits snugly into the bottom of the lower clamp. (You may need to lightly tap the bracket with a leather or rubber mallet.)
8. Unlock the handle as described in Steps 2 and 3 and slide the entire bracket upward approximately ⅛" to ⅜" or until the unit will lock into place tightly. **⚠ CAUTION:** Be careful not to have the clamps too tight when in the locked position.
9. Snug down rear screw (6) and then securely tighten front screw (5) and the rest of the screws (5 & 6) to approximately 100-125 in-lbs. Do not over-tighten middle screw (5).

Figure 1

### DIMENSIONAL SPECIFICATIONS

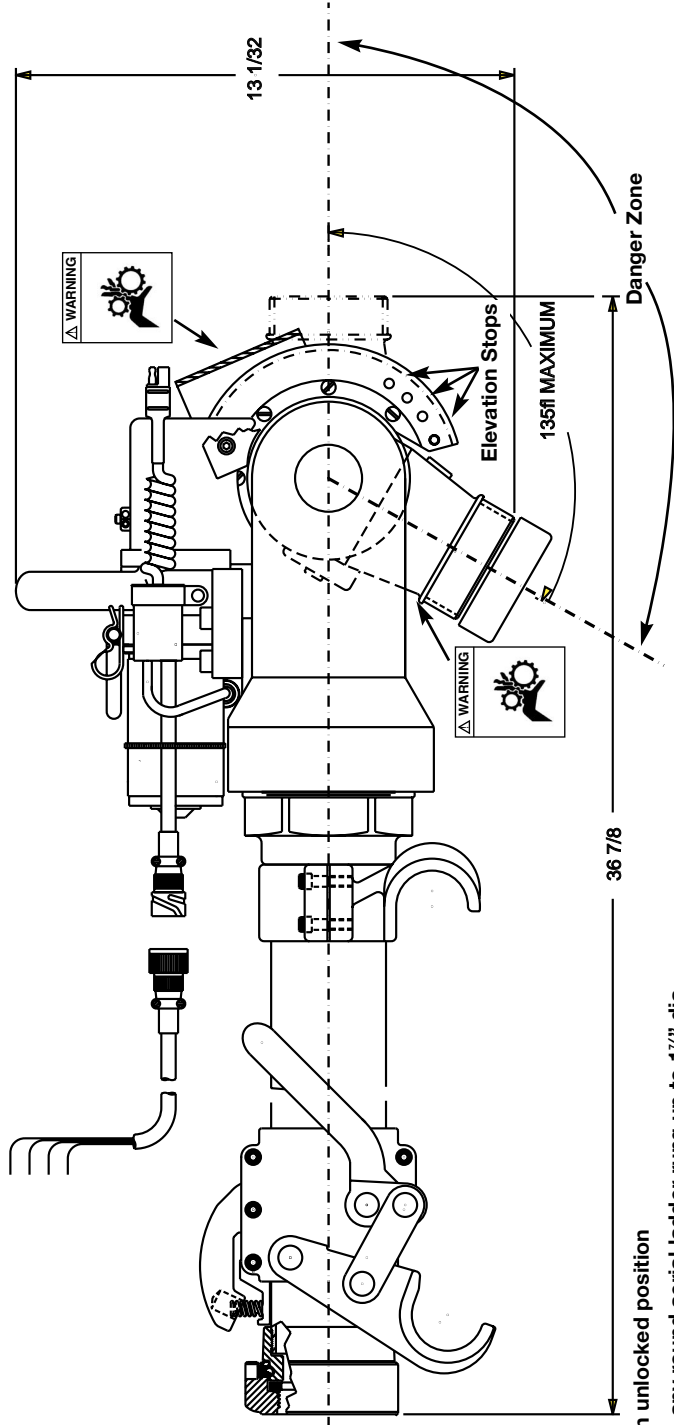
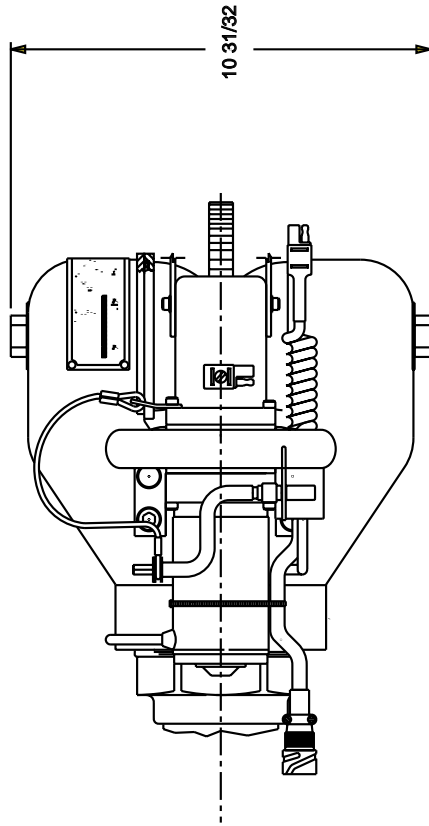

Note: View in unlocked position  
Adjustable to any round aerial ladder rung up to  $1\frac{1}{8}$ " dia.  
Rung spacing should not exceed 16" on centers for  $2\frac{1}{2}$ " and 3" swivel,  $14\frac{1}{16}$ " on centers for  $3\frac{1}{2}$ " swivel.



Figure 3

# ELECTRICAL COMPONENT LAYOUT

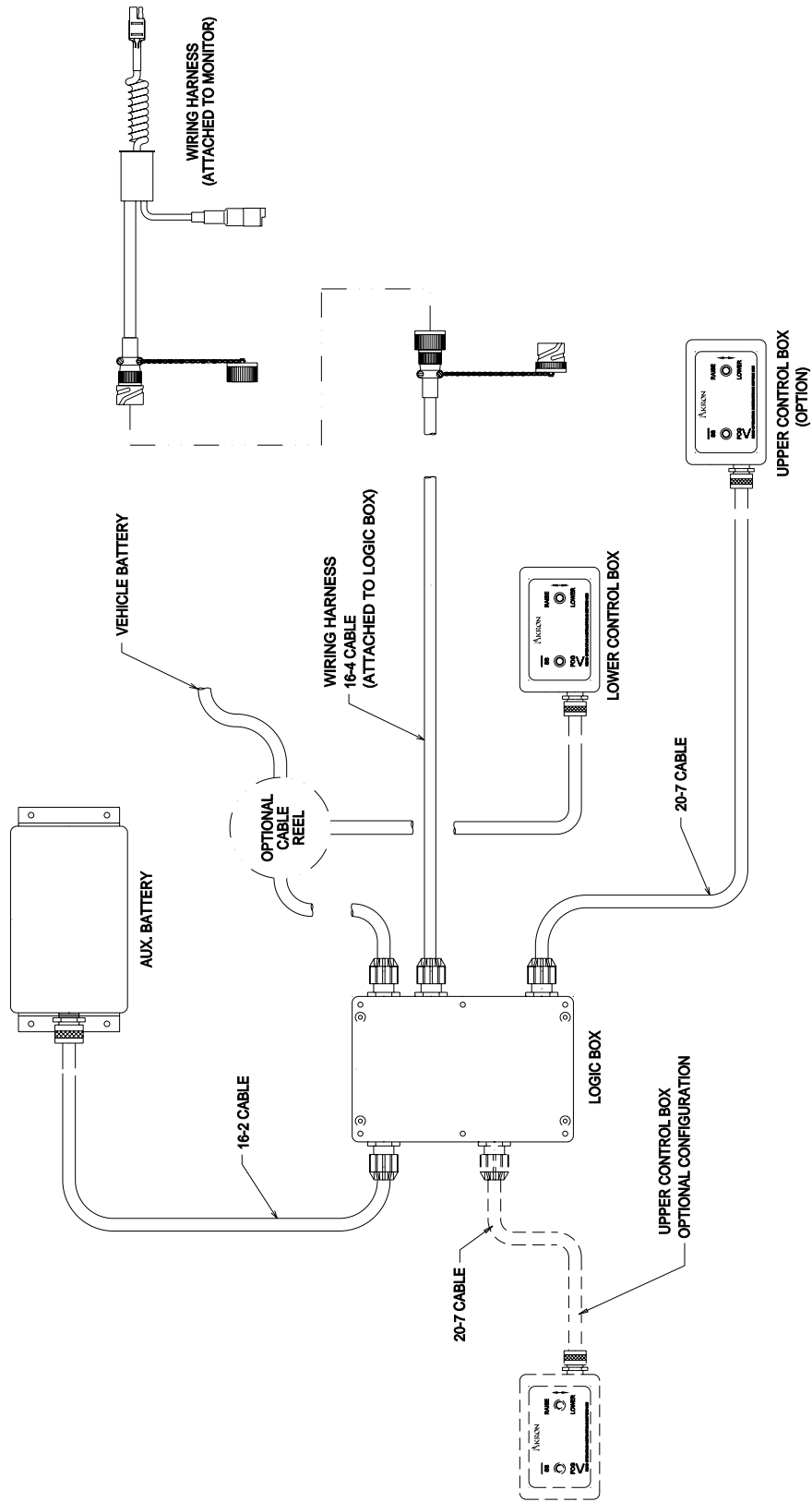

Controller Symbols	
—	Straight
<	Fog
→	Right
↑	Up

Figure 4

MONITOR  
ATTACHMENT

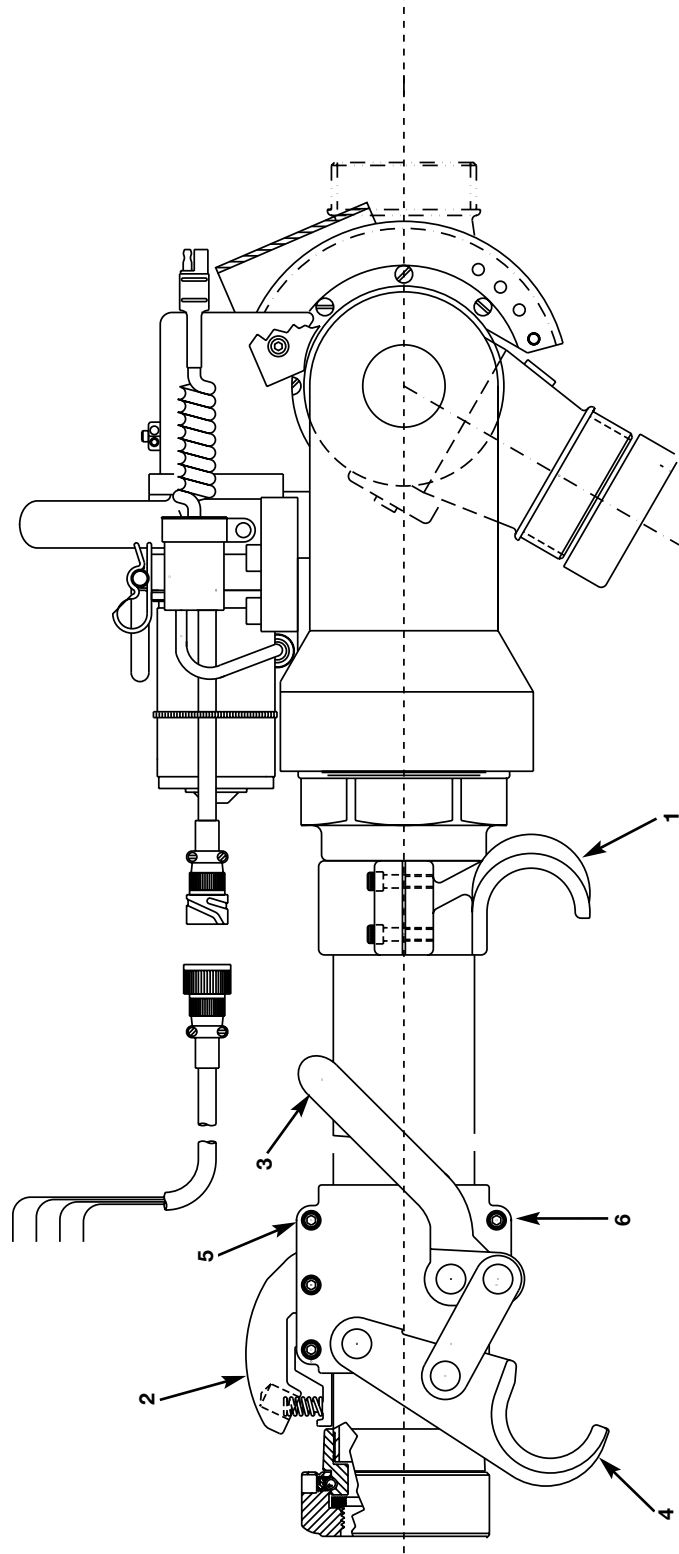

10. Test the safety catch operation to ensure proper locking action before putting the unit into service.

**NOTE:** Periodically check for wear between the safety catch (2) and the locking handle (3). If excessive wear should become apparent, the locking mechanism should be replaced immediately.

## OPERATING INSTRUCTIONS

### A. UPPER AND LOWER CONTROL OPERATION

The upper and lower control boxes are used to control the monitor and nozzle. To change the nozzle pattern toward the “straight stream” or “fog” position press the proper toggle switch toward “STRAIGHT” or “FOG” respectively. To change the vertical monitor position upward or downward press the proper toggle switch toward “RAISE” or “LOWER” respectively.

THE LOWER CONTROL BOX FUNCTIONS WILL OVERRIDE THE UPPER CONTROL BOX FUNCTIONS IN COMPLIANCE WITH THE REQUIREMENTS OF THE NFPA STANDARD. NOTE: THE LOWER CONTROL AND UPPER CONTROL WIRES MUST BE ATTACHED TO THE CORRECT TERMINALS FOR THE LOWER CONTROL TO OVERRIDE THE UPPER CONTROL. NONE OF THE FUNCTIONS CAN BE CONTROLLED FROM THE UPPER CONTROL BOX WHEN ANY OF THE SWITCHES ON THE LOWER CONTROL BOX ARE ACTIVATED.

### B. ELEVATION STOPS

The elevation stop sets the upper limit of the elevation. The monitor is shipped with the elevation stop at 90° above horizontal and can travel 45° below horizontal. The vertical position of 45°, 60° and 75° above horizontal can be achieved by switching the stop to the desired locations located on the elevation gear (Figure 1).

### C. MANUAL OVERRIDE CONTROL

THE MANUAL OVERRIDE CONTROL IS TO BE USED WHEN THE POWER TO THE MONITOR IS OFF. One override crank is attached, for the vertical control. It is ¼ inch in size. A ¼ inch Allen wrench will also actuate the overrides. To use the manual override pull the key pin which holds the override crank in place and insert the hex head end of the override crank in the hexagon shaped hole beside the crank storage bracket. Then rotate or spin the override crank either clockwise or counterclockwise to aim the monitor in the desired direction.

WHEN THE OVERRIDE CRANKS ARE NO LONGER IN USE PUT THEM BACK IN THE STORAGE POSITION. DO NOT USE THE ELECTRIC CONTROLS WHEN THE OVERRIDE CRANKS ARE BEING USED OR ARE IN POSITION FOR USE.

### D. NOZZLE PRESSURE

Do not exceed the following discharge pressure with straight tips.

<u>Tip Size</u>	<u>Pressure</u>
1¼"	100 PSI (690 KPA)
1⅜"	100 PSI (690 KPA)
1½"	100 PSI (690 KPA)
1¾"	100 PSI (552 KPA)
2"	70 PSI (488 KPA)

Do not exceed 1000 GPM (3800 LPM) when using a fog nozzle.

## MAINTENANCE INSTRUCTIONS

Your Electric Ladder Pipe monitor and nozzle should be inspected prior to and after each use, to ensure it is in good operating condition. Periodically, an unanticipated incident occurs where the Ladder Pipe is misused in a manner that is inconsistent with standard operating practices and those listed in IFSTA. A partial list of potential misuse includes:

- Operating above maximum rated pressure and flow.
- Not draining, and allowing water to freeze inside.
- Prolonged exposure to temperatures above 130°F, or below -25°F.
- Operating in a corrosive environment.
- Having the Ladder Pipe nozzle hit a fixed object during operating or transportation.
- Other misuse that might be unique to your specific environment.

Also there are many “tell tale” signs that indicate repair is in order, such as:

- Controls that are either inoperable or difficult to operate.
- Excessive wear.
- Poor discharge performance.
- Water leaks.

If any of the above situations are encountered, the Electric Ladder Pipe should be taken out of service, repaired, and tested by a qualified technician before placing it back in service.

## **MOTOR REPLACEMENT**

To replace the vertical rotational motor:

- 1) Disconnect Power from the unit.
- 2) Loosen and remove the four socket screws (Item 23 on the Parts List) from the gearbox housing.
- 3) Slowly remove the motor assembly (25) and motor adapter (6) from the unit.
- 4) Loosen and remove the 4 socket head capscrews (26) from the inside of the motor adapter that hold the housing and the motor assembly together.
- 5) Remove motor adapter (6) from the motor assembly (25).
- 6) Replace both O-ring seals (21 & 27) on the motor adapter (6).
- 7) Attach the new motor assembly (25) to the motor adapter (6) making sure all four screws (26) are tight.
- 8) Install the motor and motor adapter assembly to the unit making sure all four socket screws (23) are tight. It may be necessary to rotate the motor slightly to get the motor gear to line up with the gears inside the gearbox.
- 9) Restore power to the unit.
- 10) Test the operation of the unit.

Call Akron Brass Customer Service Department if any problems are encountered.

NOTES



ISO 9001 REGISTERED COMPANY

PHONE: 330.264.5678 or 800.228.1161 | FAX: 330.264.2944 or 800.531.7335 | [www.akronbrass.com](http://www.akronbrass.com)  
Available in Canada through AKRON MANUFACTURING COMPANY  
PHONE: 519.773.8431 | FAX: 519.773.3794

REVISED 05/03

WARRANTY AND DISCLAIMER: We warrant Akron Brass products for a period of five (5) years after purchase against defects in materials or workmanship. Akron Brass will repair or replace product which fails to satisfy this warranty. Repair or replacement shall be at the discretion of Akron Brass. Products must be promptly returned to Akron Brass for warranty service.

We will not be responsible for: wear and tear; any improper installation, use, maintenance or storage; negligence of the owner or user; repair or modification after delivery; damage; failure to follow our instructions or recommendations; or anything else beyond our control. WE MAKE NO WARRANTIES, EXPRESS OR IMPLIED, OTHER THAN THOSE INCLUDED IN THIS WARRANTY STATEMENT, AND WE DISCLAIM ANY IMPLIED WARRANTY OF MERCHANTABILITY OR FITNESS FOR ANY PARTICULAR PURPOSE. Further, we will not be responsible for any consequential, incidental or indirect damages (including, but not limited to, any loss of profits) from any cause whatsoever. No person has authority to change this warranty.

© Premier Farnell Corporation. 2000 All rights reserved. No portion of this can be reproduced without the express written consent of Premier Farnell Corporation.

**A Premier Farnell Company**