



ELECTRIC MOTOR REPLACEMENT INSTALLATION INSTRUCTIONS

To replace either the horizontal or vertical rotational motors:

1. Disconnect Power from the unit.
2. Loosen and remove the four socket screws (Item 4) from the gearbox housing (52).
3. Slowly remove the motor assembly (59) and gearbox housing (52) from the unit.
IMPORTANT: Make sure the internal gear (Item 47) remains in place (hold with a screwdriver) to avoid gear alignment problems.
4. Loosen and remove the four socket head cap screws (51) from the inside of the gearbox housing that holds the housing and the motor assembly together.
5. Remove gearbox housing (52) from the motor assembly (59).
6. Replace both O-Ring seals (50 & 53) on the gearbox housing (52).
7. Attach the new motor assemble (59) to the gearbox housing (52) making sure all four screws (51) are tight.
8. Install the motor and gearbox housing assembly to the unit making sure all four socket screws are tight (use Loctite or equivalent). It may be necessary to rotate the motor slightly to get the motor gear to line up with the gears inside the gearbox.
Hint: Use the manual override socket to rotate the gears.
9. Restore power to the unit.
10. Test the operation of the unit.

Call Akron Brass Customer Service Department if any problems are encountered.

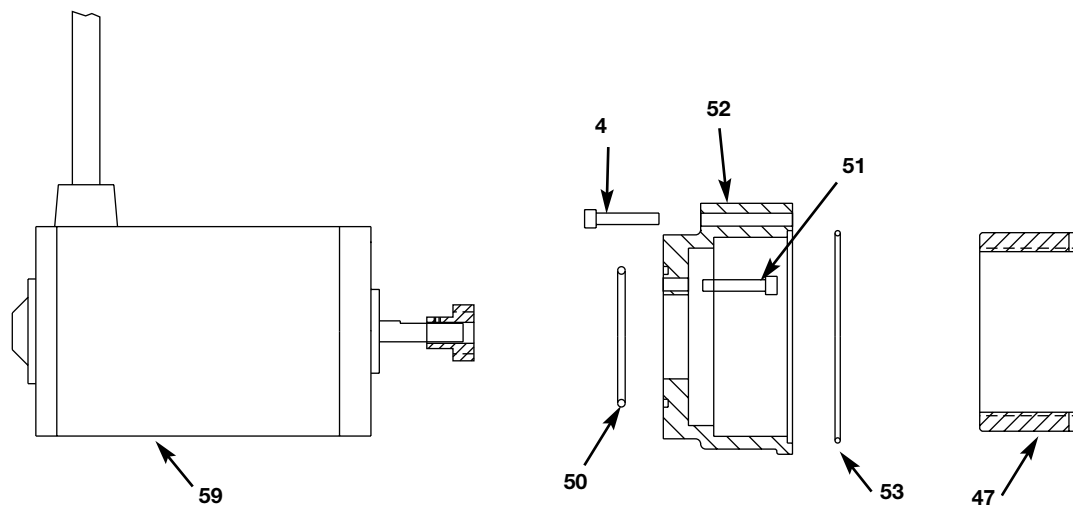



ISO 9001 REGISTERED COMPANY

PHONE: 330.264.5678 or 800.228.1161 | FAX: 330.264.2944 or 800.531.7335 | www.akronbrass.com
Available in Canada through AKRON MANUFACTURING COMPANY
PHONE: 519.773.8431 | FAX: 519.773.3794

REVISED 09/02

WARRANTY AND DISCLAIMER: We warrant Akron Brass products for a period of five (5) years after purchase against defects in materials or workmanship. Akron Brass will repair or replace product which fails to satisfy this warranty. Repair or replacement shall be at the discretion of Akron Brass. Products must be promptly returned to Akron Brass for warranty service.

We will not be responsible for: wear and tear; any improper installation, use, maintenance or storage; negligence of the owner or user; repair or modification after delivery; damage; failure to follow our instructions or recommendations; or anything else beyond our control. WE MAKE NO WARRANTIES, EXPRESS OR IMPLIED, OTHER THAN THOSE INCLUDED IN THIS WARRANTY STATEMENT, AND WE DISCLAIM ANY IMPLIED WARRANTY OF MERCHANTABILITY OR FITNESS FOR ANY PARTICULAR PURPOSE. Further, we will not be responsible for any consequential, incidental or indirect damages (including, but not limited to, any loss of profits) from any cause whatsoever. No person has authority to change this warranty.

© Premier Farnell Corporation. 2000 All rights reserved. No portion of this can be reproduced without the express written consent of Premier Farnell Corporation.

A Premier Farnell Company