



**NOTE:** Use Parker O-Ring lubricant or equivalent petroleum base lubricant for all O-Rings. Lubricate all O-Rings before assembly. **DO NOT lubricate the ball shutoff.**

1. Replace the trunnion O-Ring (2) and the trunnion bearing O-Ring (1).
2. Turn the ball (8) to the open position.
3. Insert the trunnion (L) into the valve body and align it in the ball slot.
4. Slide the trunnion bearing (K) down over the trunnion (L).
5. Position the trunnion bearing (K) for the desired handle position.
6. Install the four (4) screws (I) to secure the trunnion bearing (K) to the body (C).
7. Place the handle (H) on the splines of the trunnion (L) in the open position. (The ball should still be in the open position from Step #2.)
8. Replace the washer (M) and large socket head cap screw (G).

# STYLE 9128 FIELD SERVICE KIT FOR

**828 2 1/2" VALVE (FULL FLOW)**  
**1573 WATER THIEF 2 1/2"**  
**1582 WYE\***  
**1583 WYE\***  
**1828 HYDRANT VALVE**  
**2582 WYE\*\***  
**2583 WYE\*\***

**\* Requires two kits**  
**\*\* Requires three kits**



ISO 9001 REGISTERED COMPANY

PHONE: 330.264.5678 or 800.228.1161 | FAX: 330.264.2944 or 800.531.7335 | [www.akronbrass.com](http://www.akronbrass.com)  
Available in Canada through AKRON MANUFACTURING COMPANY  
PHONE: 519.773.8431 | FAX: 519.773.3794

REVISED 08/96

WARRANTY AND DISCLAIMER: We warrant Akron Brass products for a period of (3) years after purchase against defects in materials or workmanship. Akron Brass will repair or replace product which fails to satisfy this warranty, repair or replacement shall be at the discretion of Akron Brass. Products must be promptly returned to Akron Brass for warranty service.

We will not be responsible for: wear and tear; any improper installation, use, maintenance or storage; negligence of the owner or user; repair or modification after delivery; damage; failure to follow our instructions or recommendations or anything else beyond our control. WE MAKE NO WARRANTIES, EXPRESS OR IMPLIED, OTHER THAN THOSE INCLUDED IN THIS WARRANTY STATEMENT, AND WE DISCLAIM ANY IMPLIED WARRANTY OF MERCHANTABILITY OR FITNESS FOR ANY PARTICULAR PURPOSE. Further, we will not be responsible for any consequential, incidental or indirect damages (including, but not limited to, any loss of profits) from any cause whatsoever. No person has authority to change this warranty.

© Premier Farnell Corporation, 2009. All rights reserved. No portion of this can be reproduced without the express written consent of Premier Farnell Corporation.

**A Premier Farnell Company**

## **INSTRUCTIONS FOR INSTALLING THE PARTS IN THIS KIT DISASSEMBLY**

### **VALVE BODY**

**NOTE: This kit includes extra O-Rings for the different variations of valves. Identify the correct replacement O-Rings when removing the old ones.**

1. Remove the four (4) hex bolts (A) which hold the outlet adapter (B) to the body (C). Remove the adapter (B) from the valve body.
2. Using a face spanner (found in the Style 9200 tool kit), unscrew the seat housing (D) and remove it from the valve body (C). (This is a fine thread and if the valve has been in service for a long period of time, it may be difficult to remove.)
3. Remove the two O-Rings (6 & 7) on the seat housing (D).
4. Install the seat retaining ring tool (found in the Style 9200 tool kit), in a vice with the correct size up. Place the seat housing (D) over the tool and fit the tool into the notches in the seat retaining ring (E).
5. Use the face spanner on the seat housing (D) to remove the seat retaining ring (E) from the housing. If the valve has been in service for a long time, it may be necessary to clean the threads for the seat retaining ring (E) with a hand-held wire brush.
6. Remove the seat (5) and O-Ring (4) from the seat housing (D), if so equipped.
7. Remove the threaded trunnion (F) from the bottom of the valve. Remove the old O-Ring (3).
8. Rotate the valve to the open position and remove the ball (8).

**NOTES: There have been several different seats used over the years that may look different from the new seat in the service kit. The kit seat is a universal replacement. The plastic ball in the kit will fit valves equipped with a metal ball. The slot in the new ball may be 90 degrees from the slot in the original ball. To install the new ball, place it in the valve in the open position. Adjustment of the handle stop may be required to maintain the same handle, open/close quadrant.**

### **ASSEMBLY - VALVE BODY**

**NOTE: Use Parker O-Ring lubricant or equivalent petroleum base lubricant for all O-Rings before assembly. Do not lubricate the valve ball (8).**

1. Replace the threaded trunnion O-Ring (3).
2. Replace the ball (8) in the valve body (C) and install the trunnion (F).
3. Install the O-Ring (4) and seat (5) into the seat housing (D). Install the seat retaining ring (E).
4. Tighten the seat retaining ring (E), using the face spanner and seat retaining ring tool, until snug. **DO NOT OVER TIGHTEN.**
5. Install the two (2) seat housing O-Rings (6 & 7) and thread the seat housing subassembly (D) into the body (C).
6. With the ball in the closed position, adjust the seat housing until resistance is felt when opening and closing the valve. The seat (5) should just touch the ball (8). (Over tightening will cause excessive valve wear and make the valve difficult to operate.)
7. Place the valve in the closed position and test as follows:
  - A. If the valve is out of the truck, hold the valve with the inlet side up and fill the body with water.
  - B. If the valve is in the truck, allow the water to flow into the valve. Observe the outlet of the valve. If a leak is found, the seat housing can be tightened a 1/16 of a turn at a time with the face spanner until the leak is stopped.
8. Replace the adapter (B) and tighten the four (4) bolts (A) in an "X" pattern.

### **ADJUSTMENT AND REPAIR OF R\* AND Y\* TYPE HANDLES**

#### **DISASSEMBLY - TOP TRUNNION ASSEMBLY**

1. Remove the socket head cap screw (G) that holds the handle (H) on.
2. Remove the handle from the trunnion (L). The screw that protrudes is a stop screw (J) and should be left in place unless replacing these parts.
3. Remove the four (4) recessed screws (I) which secure the trunnion bearing (K) to the body (C).
4. Pull out the trunnion (L) and trunnion bearing (K). Push the trunnion (L) out of the bottom of the trunnion bearing (K). This will expose the last two (2) O-Rings (1 & 2) which are supplied in the service kit.

**NOTE: There are eight (8) threaded holes in the top of the body (C) which allow for the various handle positions.**

#### **ASSEMBLY - TOP TRUNNION ASSEMBLY**

**STYLE 1582/1583**

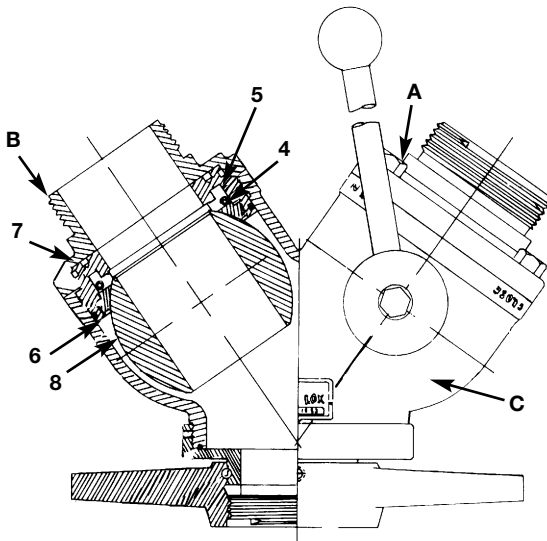

**STYLE 2582/2583**

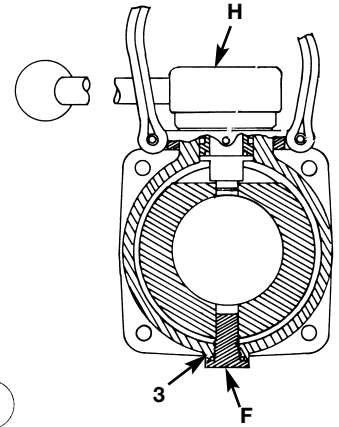
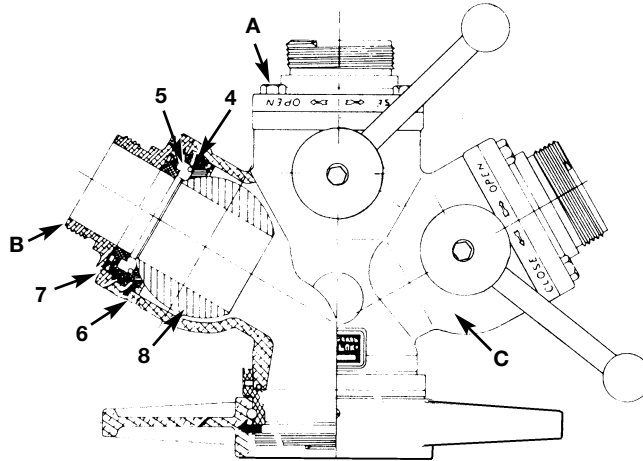

**STYLE 1828**

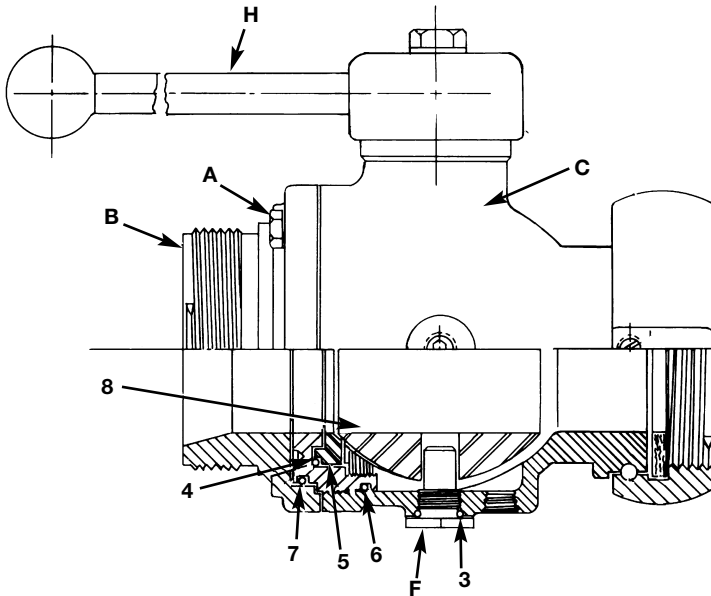

**STYLE 1573 2 1/2" VALVE ONLY**

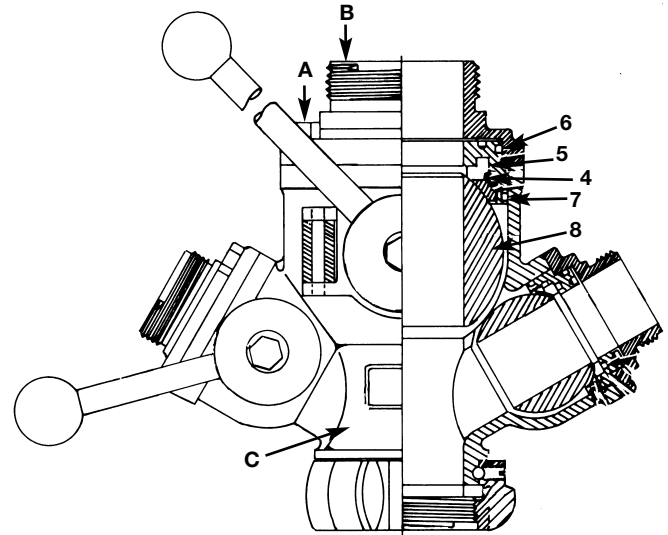

**STYLE 828 2 1/2" VALVE**

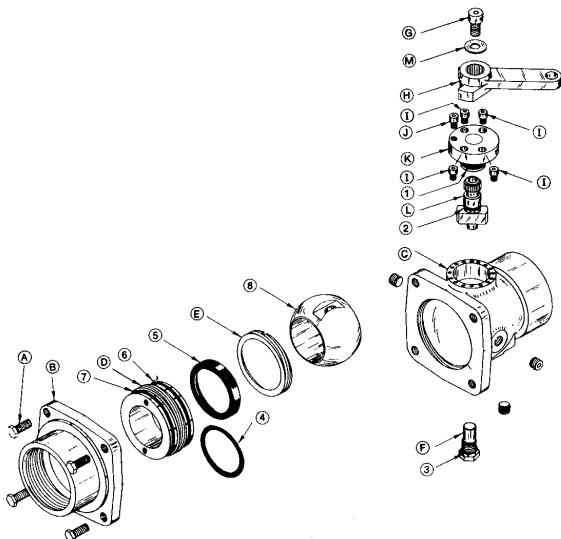

ITEM NO.	DESCRIPTION	PART NUMBER
1	O-Ring Trunnion Bearing	7-57-010
2	O-Ring Trunnion	7-57-008
3	O-Ring Threaded Trunnion	7-57-198
4	O-Ring Seat	7-57-035
5	Valve Seat	7-69-156
6	O-Ring Seat Housing	7-57-073
7	O-Ring Adapter	7-57-017
8	Valve Ball	7-03-429

# STYLE 9128

USE THESE ILLUSTRATIONS TO IDENTIFY THE VARIOUS PARTS IN THIS KIT

Item No. 1  
PN #7-57-010  
O-Ring  
Trunnion Bearing

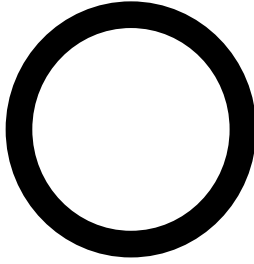

Item No. 2  
PN #7-57-008  
O-Ring  
Trunnion

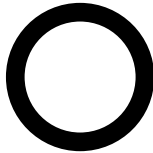

Item No. 3  
PN #7-57-198  
O-Ring  
Threaded Trunnion

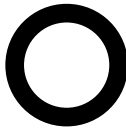

Item No. 5  
PN #7-69-156  
Valve Seat

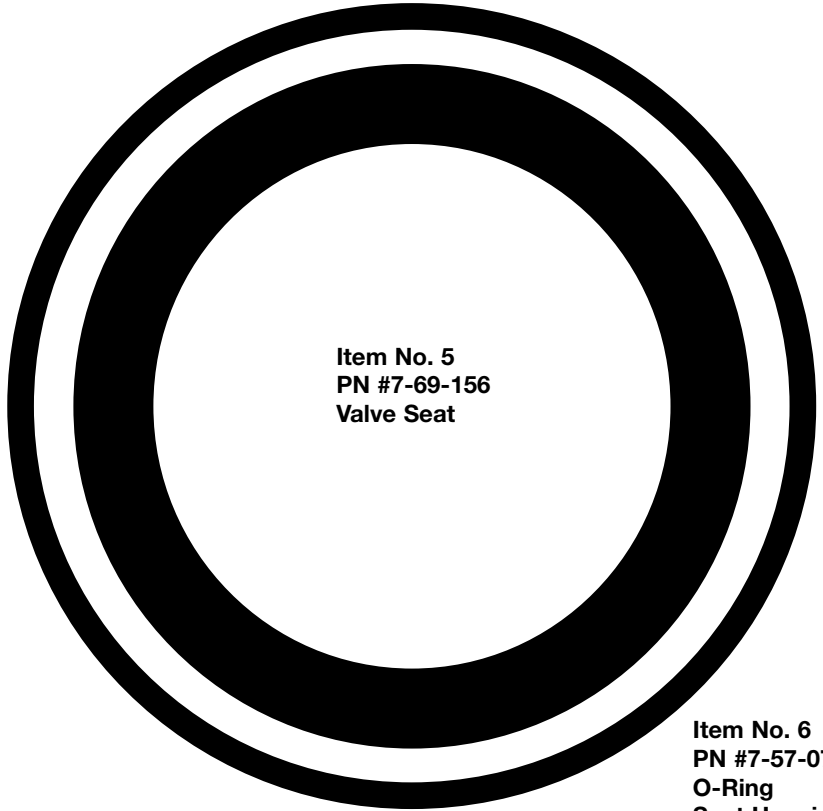

Item No. 6  
PN #7-57-073  
O-Ring  
Seat Housing

Item No. 4  
PN #7-57-035  
O-Ring  
Seat



Item No. 7  
PN #7-57-017  
O-Ring  
Adapter

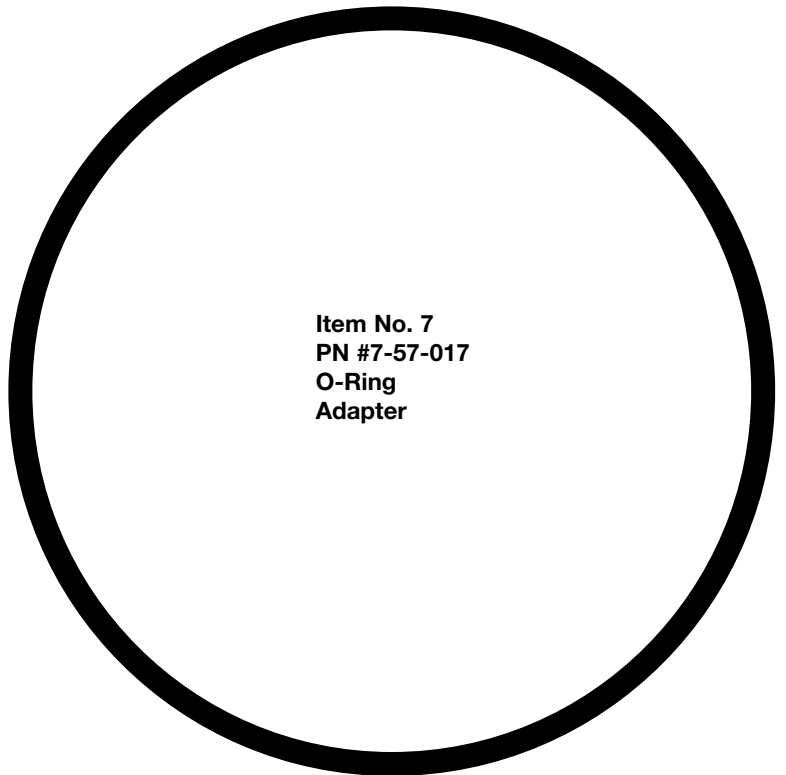

Item No. 8  
PN #7-03-429 (Not Illustrated)  
Valve Ball