



Style 9106 Field Service Kit for

1708 1" Turbojet® with Pistol Grip

1708P 1" Turbojet with Pistol Grip (Pyrolite®)

1710 1" Turbojet

1710P 1" Turbojet (Pyrolite)



ISO 9001 REGISTERED COMPANY

PHONE: 330.264.5678 or 800.228.1161 | FAX: 330.264.2944 or
800.531.7335 | www.akronbrass.com
Available in Canada through AKRON MANUFACTURING COMPANY
PHONE: 519.773.8431 | FAX: 519.773.3794

REVISED 07/03

WARRANTY AND DISCLAIMER: We warrant Akron Brass products for a period of five (5) years after purchase against defects in materials or workmanship. Akron Brass will repair or replace products which fail to satisfy this warranty. Repair or replacement shall be at the discretion of Akron Brass. Product must be promptly returned to Akron Brass for warranty service.

We will not be responsible for wear and tear, any improper installation, use, maintenance or storage; negligence of the owner or user; repair or modification after delivery; damage; failure to follow our instructions or recommendations or anything else beyond our control. **WE MAKE NO WARRANTIES, EXPRESS OR IMPLIED, OTHER THAN THOSE INCLUDED IN THIS WARRANTY STATEMENT. AND WE DISCLAIM ANY IMPLIED WARRANTY OF MERCHANTABILITY OR FITNESS FOR ANY PARTICULAR PURPOSE.** Further, we will not be responsible for any consequential, incidental or indirect damages (including, but not limited to, any loss of profits) from any cause whatsoever. No person has authority to change this warranty.

© Premier Farnell Corporation, 2000. All rights reserved. No portion of this article reproduced without the express written consent of Premier Farnell Corporation.

A Premier Farnell Company

Style 9106 Field Service Kit

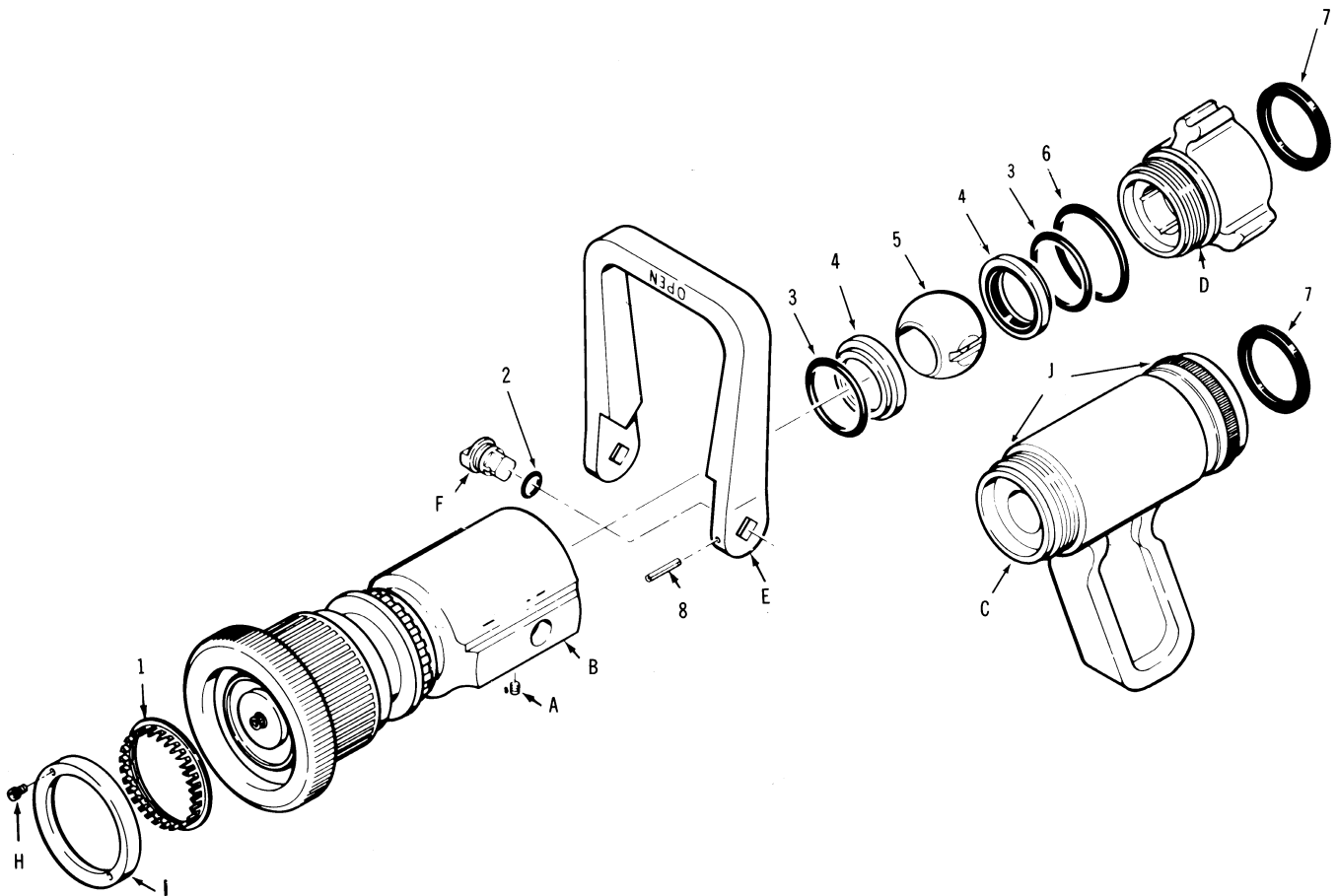

ITEM NO.	DESCRIPTION	PART NO.
1	Turbine Teeth	7-72-189
2	O-Ring (2)	7-57-005
3	O-Ring (2)	7-57-052
4	Seat (2)	7-69-244
5	Ball	101837
6	O-Ring	7-57-054
7	Gasket 1"	7-17-047

Parts included in this kit are normally all that are required to repair leaks in the shutoff area. If additional nozzle components are required, contact Akron Brass for the appropriate technical service bulletin or return the nozzle to our factory: Akron Brass Co., Old Mansfield Rd., Wooster, Ohio 44691 or Akron Manufacturing Co., P.O. Box 280, Aylmer, Ontario N5H 2R9.

FIELD SERVICE KIT INSTRUCTIONS

DISASSEMBLY

1. Remove the swivel gasket (7).
2. Remove the set screw (A) at the swivel end of the shut-off body (B). Depending on the age of the nozzle, it will require a 1/8" Allen wrench (for a 1/4-20 screw) or a 3/32" Allen wrench (for a 10-24 screw).
3. a) For Style 1708, unscrew the pistol grip (C) from the shutoff body.
b) For Styles 1708P and 1710P insert a tool 7/16" square into the grooves in the swivel adapter (D) and remove (counterclockwise).
c) For Style 1710, unscrew the rigid base (E) with a strap wrench.
4. Remove the O-Ring (6) from the inlet adapter (C OR D).
5. Remove the seat and O-Ring (4 and 3) from the inlet adapter (C or D).

NOTE: Any plastic spacer ring(s) must remain in the inlet adapter recess under the seat and O-Ring for proper reassembly.

6. Turn the handle (E) into the open position and remove the ball (5).

NOTE: If the nozzle was manufactured prior to 1968, the handle must be turned to the closed position to

remove the ball. If this is the case, new trunnions and possibly a new handle will be required to install the new ball. Please contact the factory for complete information (330-264-5678).

7. Mark the end of the trunnions (F) and handle so they can be reassembled in exactly the same position. (Use chalk, grease pencil, etc.).
8. Take the rivet supplied in the service parts kit and drive out the roll pins (8) securing the handle to the trunnions.
9. Push the trunnions into the shutoff body until they are free. Remove the handle and trunnions.
10. Remove the O-Rings (2) from the trunnions.
11. Remove the front seat and O-Ring (4 and 3). Depending on the age of the nozzle the seat may not have an O-Ring. The new seats must be installed with an O-Ring.
12. Remove the two set screws (H) on the turbine retaining ring (I) with a 3/32" Allen wrench.
13. Remove the turbine retaining ring.
14. Remove the turbine teeth (1).

ASSEMBLY

NOTE: All O-Rings must be lubricated with O-Ring grease before assembly.

1. Install the new O-Rings (3) on the new seats (4).
2. Insert one new seat with O-Ring into the shutoff body (B).
3. Install the new O-Rings (2) on the trunnions (F).
4. Place the handle (E) over the trunnions holes with the "closed" lettering facing the inlet.
5. Install the trunnions from inside the shutoff body, using the marks (Disassembly Step 7) to position properly.
6. Install the roll pins (8) to secure the handle to the trunnions.
7. Turn the handle into the open position and insert the new ball (5).
8. Install the other new seat with O-Ring into the recess of the inlet adapter (D), or pistol grip (C).

NOTE: To be placed above the plastic spacer ring(s) if so equipped.

9. Install the new O-Ring (6) in the shutoff body recess.
10. With the handle in the closed position:
 - a) For Style 1708, thread the pistol grip into the

shutoff body.

- b) For Style 1708P and 1710P thread the swivel adapter into the shutoff body.
- c) For Style 1710 thread the rigid base into the shutoff body.

NOTE: Continue tightening until resistance is felt when opening and closing the shutoff .

11. Install the new swivel gasket (7).
12. Install the new turbine teeth (1).
13. Line up screw holes with the holes in the nozzle body and place the turbine retaining ring (I) back into position.
14. Install and tighten the set screws (H) which secure the retaining ring.
15. Test the nozzle with water to determine if the shutoff functions properly. If a small leak is present, tighten the inlet adapter slightly to eliminate the leak.
16. Once the shutoff functions properly, observe the inlet adapter through the set screw hole in the shutoff body. If a full thread is visible, drill a slight recess for the set screw (A) (for a 10-24 set screw, use a #25 drill bit; for a 1/4-20 use a 3/16 drill bit). Install and tighten the set screw.

USE THESE ILLUSTRATIONS TO IDENTIFY THE VARIOUS PARTS IN THIS KIT

Item No. 1
PN 7-72-189
Turbine Teeth



Item No. 4
PN 7-09-244
Seat (2)

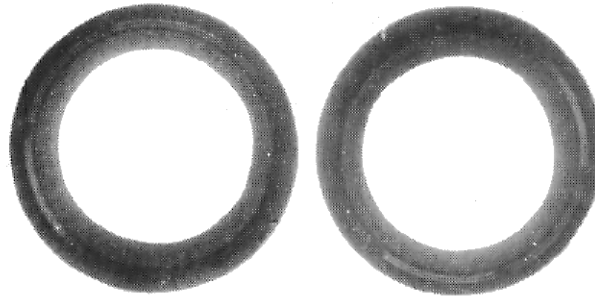

Rivet
PN 7-44-125
Use to drive out roll pins
in Handle Trunnions



Item No. 5
PN 101837
Shutoff Ball

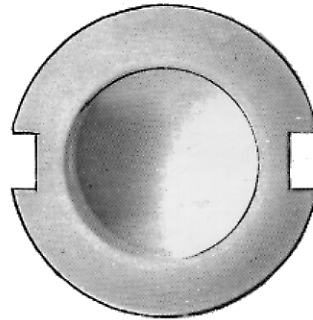

Item No. 2
PN 7-57-005
O-Rings (2)
Handle Trunnions



Item No. 6
PN 7-57-054
O-Ring
Inlet Adapter

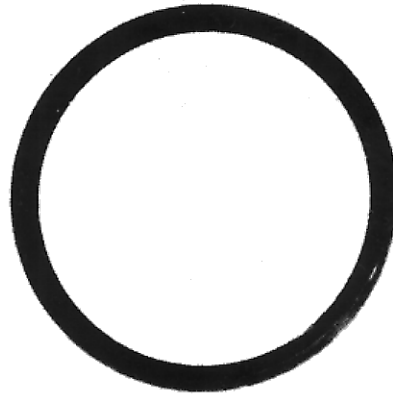

Item No. 3
PN 7-57-052
O-Rings (2)

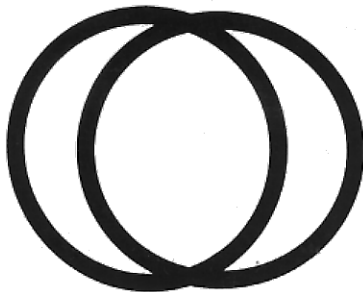

Item No. 7
PN 7-17-047
1" Swivel Gasket

